

**TOMOS AT 50**  
**BT 50**  
**ATX 50**  
**NTX 50**

**navodilo za popravilo**  
**workshop manual**

**TOMOS**



navodilo za popravilo  
workshop manual

TOMOS AT 50  
TOMOS BT 50  
TOMOS ATX 50  
TOMOS NTX 50

Tehnični podatki Technical data . . . . .	3
Motor — demontaža iz okvirja Engine — removing the engine from the frame . . . . .	9
Motor — razstavljanje Dismantling the engine . . . . .	10
Motor — kontrola delov in sklopov Engine — inspecting the engine parts and assemblies . . . . .	14
Motor — sestavljanje Re-assembling the engine . . . . .	24
Magnetni vžigalnik, nastavitve in elektroinstalacija Magneto settings and electrical equipment . . . . .	26
Dušilec, uplinjač, izpušni glušnik Intake silencer, carburettor, exhaust silencer . . . . .	36
Nosilna konstrukcija Carrying units . . . . .	40
Vilice in blažilci Front fork and shock absorbers . . . . .	42
Kolesa Wheels . . . . .	46
Zavore Brakes . . . . .	50
Oprema — rezervoar, maske, sedež Equipment — fuel tank, side covers, seat . . . . .	52
Nastavitve Settings . . . . .	53
Tabela vzdrževanja Routine maintenance chart . . . . .	55
Specialno orodje Special tools . . . . .	57
Standardno orodje Tool kit . . . . .	58
Časovni normativ Time standards . . . . .	59

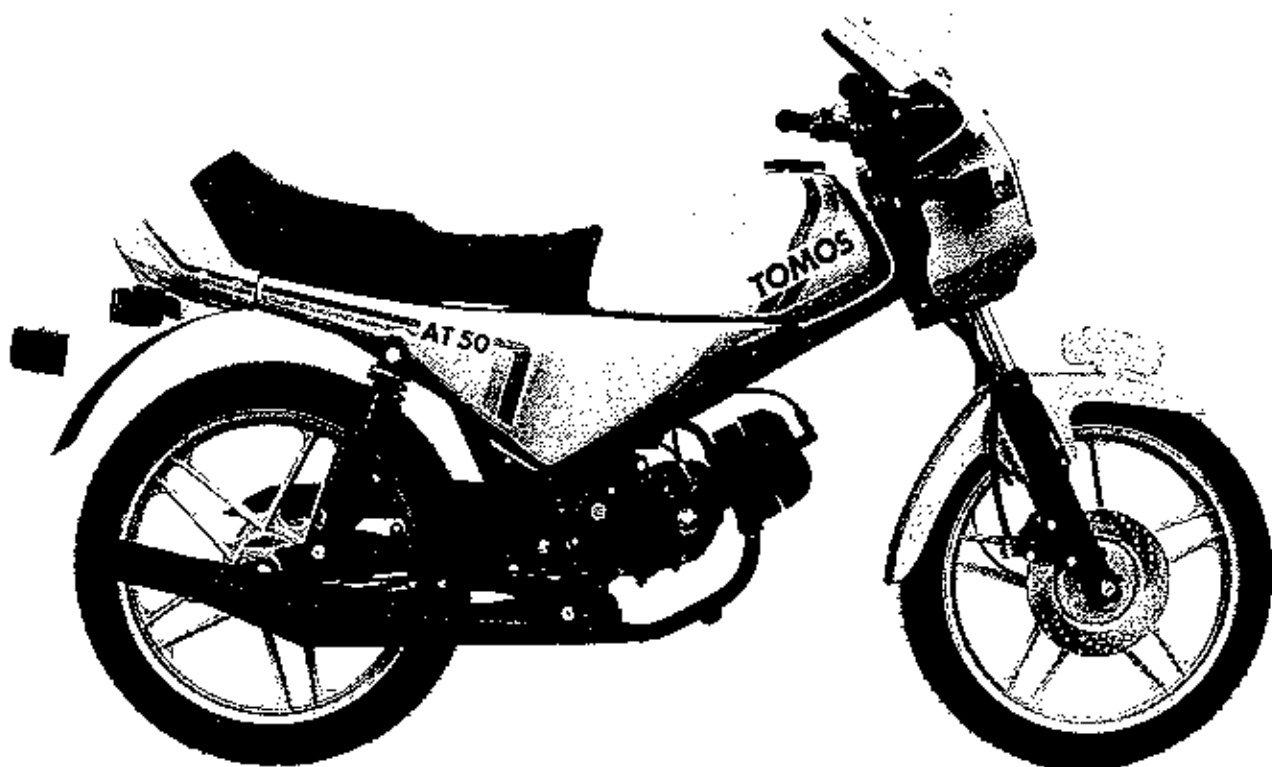
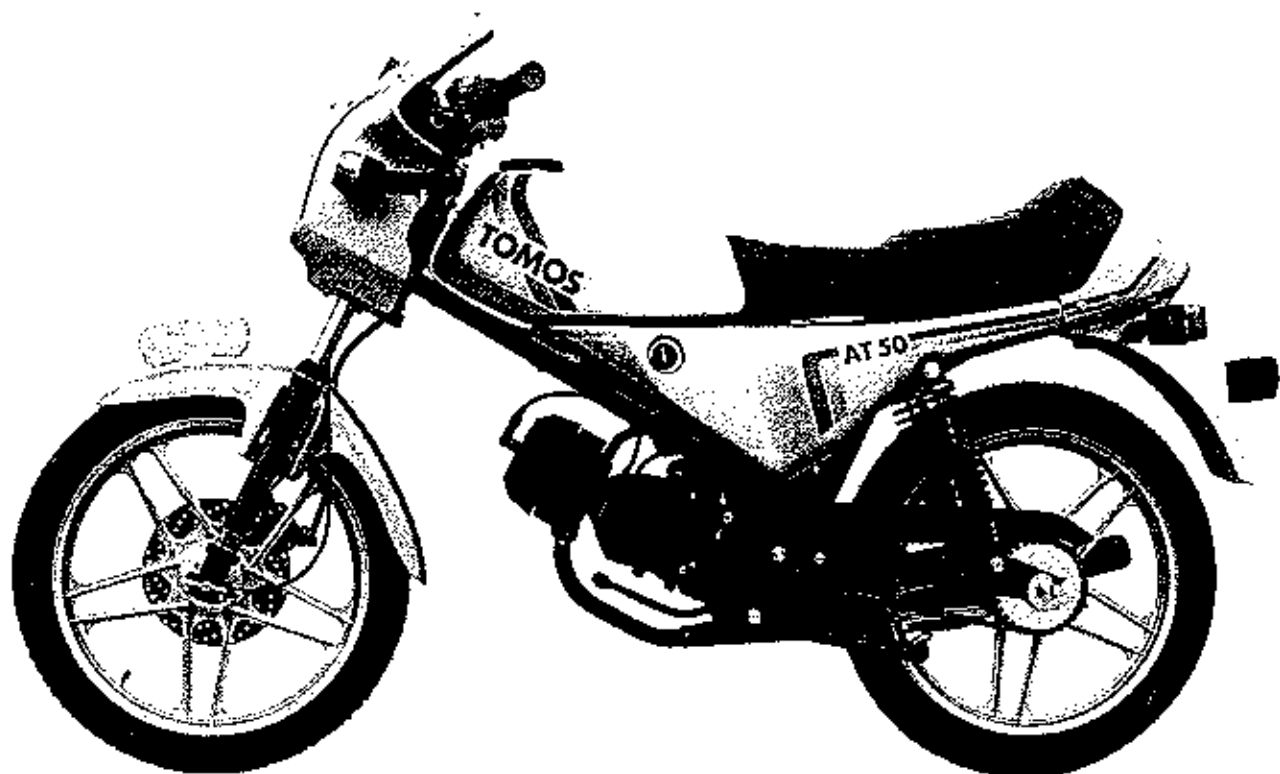

TOMOS AT 50  
TOMOS BT 50 (je po zunanjem videzu podoben  
AT 50)

— dolžina: 1815 mm  
— višina: 1125 mm  
— širina: 670 mm

TOMOS AT 50  
TOMOS BT 50 (In appearance, it is similar to the  
AT 50)

Overall length: 1815 mm  
Overall height: 1125 mm  
Overall width: 670 mm

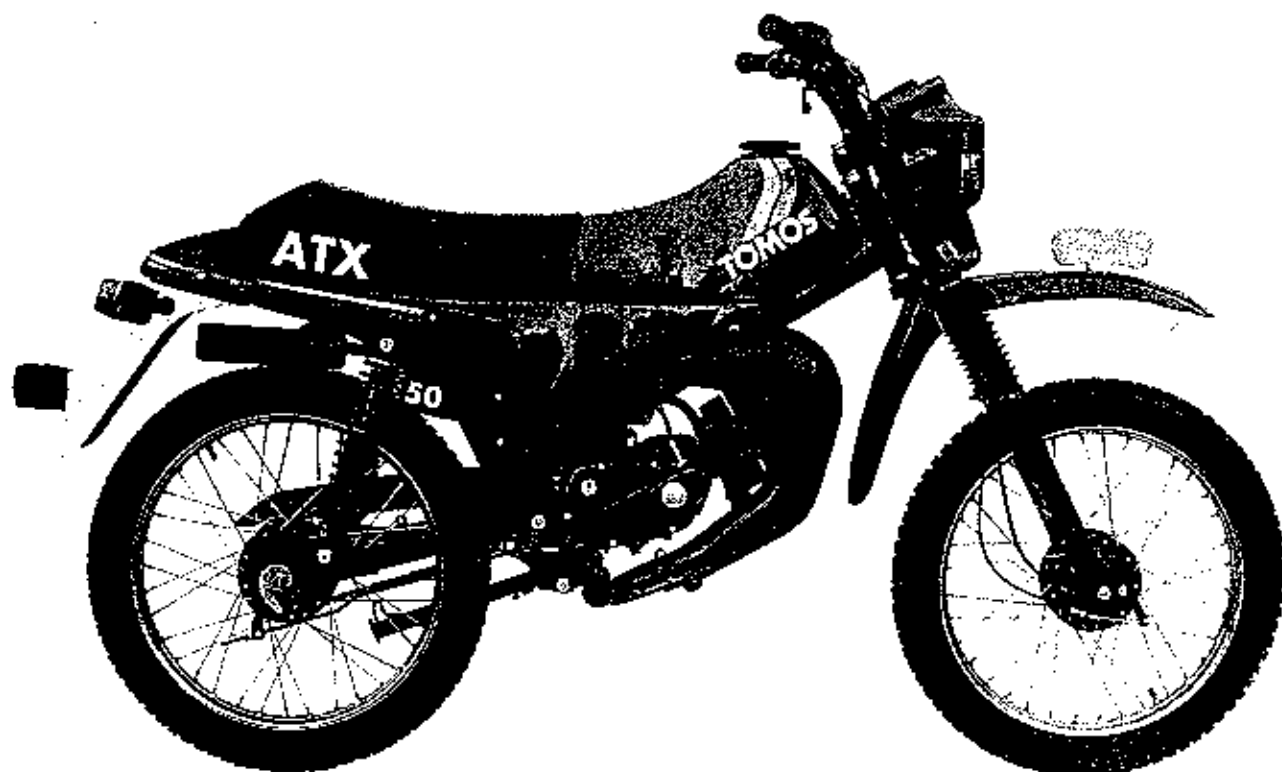

TOMOS ATX 50

— dolžina:  
— višina:  
— širina:

2010 mm  
1120 mm  
760 mm

TOMOS ATX 50

Overall length:  
Overall height:  
Overall width:

2010 mm  
1120 mm  
760 mm

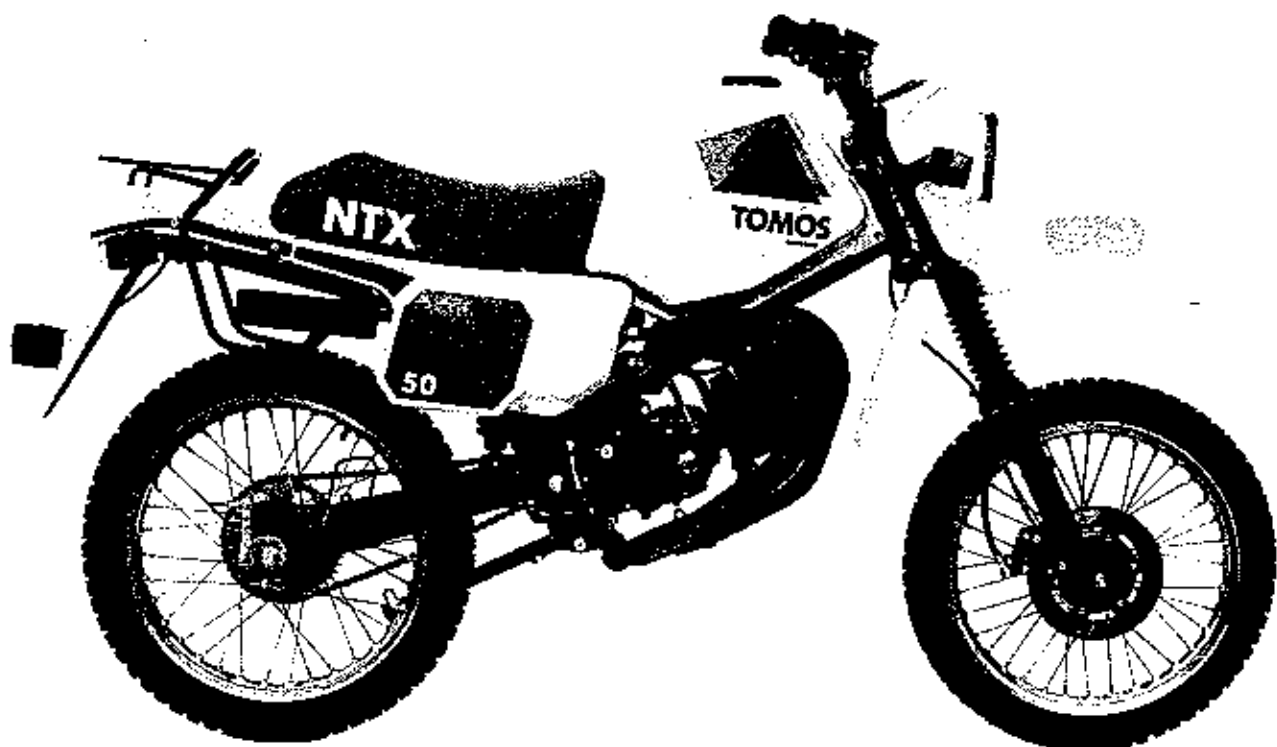
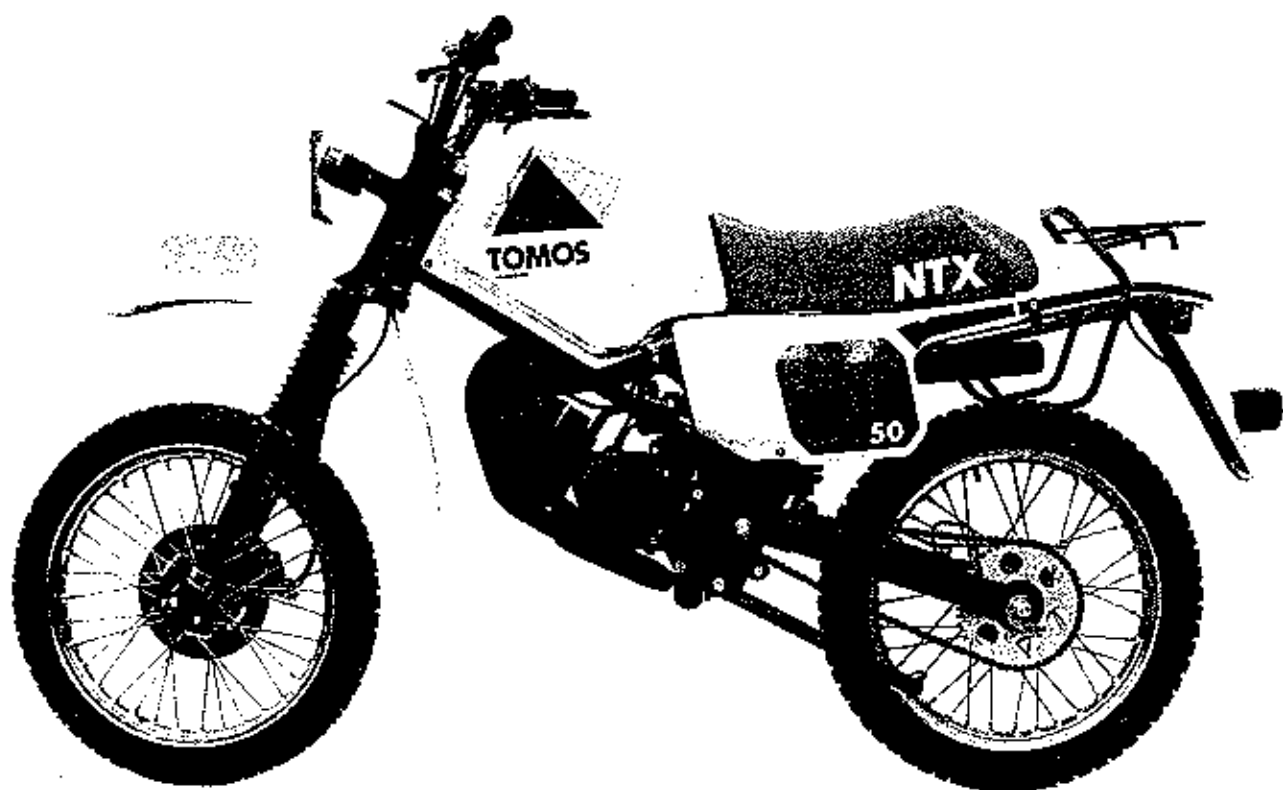

TOMOS NTX 50

— dolžina: 2010 mm  
— višina: 1120 mm  
— širina: 760 mm

TOMOS NTX 50

Overall length: 2010 mm  
Overall height: 1120 mm  
Overall width: 760 mm

MOTOR: Enovaljni, dvotaktni, zračno hlajen  
ENGINE: Single cylinder, 2-stroke, air cooled  
DELOVNA PROSTORNINA: 49 cm<sup>3</sup>  
PISTON DISPLACEMENT: 49 cc

Tip	Moč motorja (KW)	pri o/min	Kompresijsko razmerje	Max. hitrost (km/h)
Type	Engine output kW	at r.p.m.	Compression ratio	Top speed km p.h.
AT 50 I NTX 50 I	1,09	4500	7 : 1	40
ATX 50 NL NTX 50 NL	1,3	4500	7 : 1	40
AT 50 NL	1,3	4750	7,5 : 1	40
AT 50 GB, N ATX 50 GB, N, YU NTX 50 GB, N	1,6	5000	9 : 1	50
BT 50 YU	4	8000	11 : 1	80

PREDNJE VILICE: teleskopske oljno vzmetne  
FRONT FORK: Telescopic oil spring

Tip Type	BT 50	AT, ATX 50	NTX 50
Hod/mm Travel/mm	90	100	160

ZADNJI BLAŽILCI:  
AT 50, BT 50, ATX 50: par, oljno vzmetna  
hod: 60 mm  
NTX 50: centralno oljno vzmetni  
hod: 35 mm

REAR SHOCKS:  
AT 50, BT 50, ATX 50: Oil spring shocks, a pair  
Travel: 60 mm  
NTX 50: Central oil spring shocks  
Travel: 35 mm



	EM Measure Unit	AT 50	BT 50	ATX 50	NTX 50
Medosna razdalja mm Wheelbase/mm		1225	1225	1320	1225
Gume: spredaj Tyres: Front		2,5 × 17"	2,5 × 17"	2,5 × 17"	2,75 × 18"
zadaj Rear		2,75 × 17"	2,75 × 17"	2,75 × 17"	3,00 × 18"
Zavore: spredaj Brakes: Front		kolut Disc Ø 220	kolut Disc Ø 220	boben Drum Ø 105	kolut Disc Ø 220
zadaj Rear		boben Drum Ø 90	boben Drum Ø 125	boben Drum Ø 125	boben Drum Ø 110
Rezervoar Fuel tank	l litres	9,5	9,5	9,5	16
Teža vozila Weight	kg	68	70	70	74
Nosilnost Carrying capacity	kg	150	150	150	150

### MOTOR

Delovna prostornina 49 cm<sup>3</sup>  
 Premer bata 38 mm  
 Hod bata 43 mm  
 Gorivo: mešanica olja in benzina v razmerju  
 1 : 50 za AT 50, ATX 50 in NTX 50  
 1 : 25 za BT 50

### MENJALNIK

— število prestav: 4 ali 5  
 — sklopka: torna, 3 lamelna, mokra s 4 ali 6 potisnih vzmeti  
 — olje v menjalniku: SAE 30 400 cm<sup>3</sup>  
 — prestavna razmerja

	iztopna gred:	predl. gred:
I prestava	38 : 10	i = 3,800
II prestava	34 : 15	i = 2,266
III prestava	35 : 22	i = 1,590
IV prestava	31 : 25	i = 1,240
V prestava	29 : 27	i = 1,074

— primarni prenos: predležna gred: sklopka

— prestavno razmerje 61 : 15 i = 4,066

— verižni prenos: veriga 1/23/16, 100 členov

število zob verižnika na kolesu Z = 30, 31, 32, 33

število zob pogonskega verižnika Z = 10, 11, 12, 13, 14, 15

### ENGINE

Piston displacement 49 cc  
 Bore and stroke 38 × 43 mm

Fuel: Mixture of oil and petrol in the ratio of 1 : 50 with AT 50, ATX 50 and NTX 50 1 : 25 with BT 50

### GEARBOX

Gears: 4 or 5  
 Clutch: Triple friction, wet with 4 or 6 thrust springs  
 Gearbox oil: SAE 30, 400 cc

Gear ratios:

	Output shaft:	Countershaft
1st gear	3800 : 1	(10 × 38 T)
2nd gear	2266 : 1	(15 × 34 T)
3rd gear	1590 : 1	(22 × 35 T)
4th gear	1240 : 1	(25 × 31 T)
5th gear	1074 : 1	(27 × 29 T)

Primary transmission: Countershaft: Clutch

Gear ratio 4066 : 1 (15 × 61 T)

Chain transmission: Chain 1/2.3/16, 100 links

No. of teeth on the wheel chain sprocket T = 30, 31, 32, 33

No. of teeth on the drive chain sprocket T = 10, 11, 12, 13, 14, 15

Motor demontirajte iz okvirja samo pri zahtevnejših popravilih.

Popravilo na valju z batom, vžigalniku, sklopki in predležni gredi lahko opravite brez predhodne demontaže.

Da bi motor demontirali iz okvira, predhodno izpustite olje iz menjalnika in demontirajte:

- stranske maske (sl. 7)
- zagonsko in pretično ročico
- levi pokrov motorja (sl. 8)
- verigo
- električne priključke
- uplinjač
- izpušni glušnik
- bowden sklopke
- popustite drog zadnje zavore
- in na koncu nosilne vijake motorja

Remove the engine from the frame only with major repairs.

The cylinder with piston, the magneto, the clutch, and the countershaft can be repaired without removing them.

To remove the engine from the frame, first allow the gearbox oil to drain and then remove:

- Side covers (Fig. 7)
- Starter and gearshift levers
- Engine cover, LH (Fig. 8)
- Chain
- Electrical outlets
- Carburettor
- Exhaust silencer
- Clutch control cable
- Release the rear brake lever and, finally,
- Slacken the engine carrying screws.

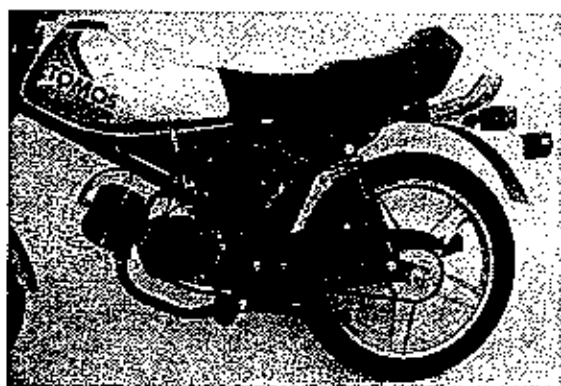

7

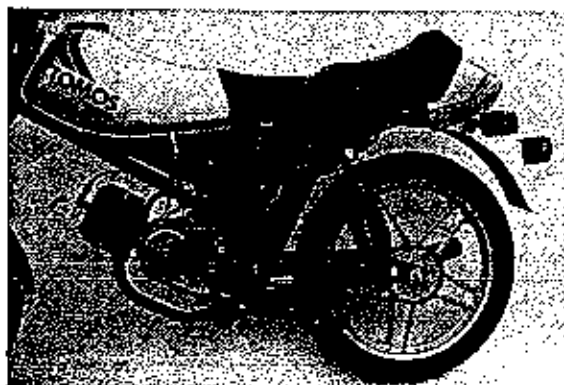

8

Motor postaviti na specialno orodje 714.011 (sl. 9). Sneti razcepko iz nastavne matice sklopke (sl. 10). Odviti matico in sneti aksialni ležaj (sl. 11 in 12). Odviti šest vijakov desnega pokrova motorja in ga s tesnilom vred ločiti od ohišja. Sneti podložke za nastavljanje aksialne zračnosti predležne gredi (sl. 13).

Sneti predležno gred z zobniki (sl. 14), iz bobna sklopke izvleči sklopko z lamelami in igličasti ležaj. Odvarovati varovalno podložko v bobnu sklopke (sl. 15).

Z orodjem 730.159 blokirati boben sklopke in odviti matico z levim navojem (sl. 16).

Boben sklopke ločiti z lažjimi udarci lesenega ali plastičnega kladiva (sl. 17).

Odviti vijaka, ki spajata ohišje na zunanjem robu (sl. 18).

Postaviti motor v pokončni položaj, sneti svečko, s cevničnim ključem 11 odviti štiri matice in sneti glavo s tesnilom (sl. 19).

Sneti valj (sl. 20) in tesnilo valja.

Sneti varovalke batnega sornika (sl. 21).

Potisniti somnik navzven ter demontirati bat (sl. 22).

Obrniti motor v vodoravni položaj (z vžigalnikom navzgor). Z orodjem št. 731.183 blokirati verižnik, odviti matico in sneti verižnik (sl. 23).

Z orodjem 732.202 blokirati magnetni vztrajnik in odviti malico vztrajnika (sl. 24).

V vztrajnik uviti orodje 736.533 (za vžigalnik CEV) ali 732.746 (za vžigalnik ISKRA-BOSCH) in ga sneti (sl. 25).

Odviti tri vijake in demontirati stator vžigalnika (sl. 26).

Odviti sedem vijakov s katerimi sta spojeni obe polovici ohišja motorja.

Na mesto statorja privijemo orodje 735.888. Z rahlimi udarci lesenega ali plastičnega kladiva po spoju ohišja in ob počasnem privijanju vijaka na orodju 735.888 iztisnemo motorno gred iz leve polovice ohišja (sl. 27).

Ko se polovici ohišja ločita 3 do 5 mm, obniti motor na podstavku (orodje 735.888 od spodaj) in nadaljevati privijanje vijaka na orodju dokler se motorna gred popolnoma ne iztisne iz levega ohišja (sl. 28). Na pripravi ostane leva polovica ohišja z zobniki menjalnika. (Paziti na podložke, ki uravnavajo aksialno zračnost gredi v menjalniku).

Motorno gred, ki ostane v desnem ohišju iztisniti ali izbiti kot prikazuje slika 29.

Iz levega ohišja sneti kompletno zagonsko gred (sl. 30).

Skupno sneti pretično in gonilno gred (sl. 31).

Place the engine on special tool 714.011. (Fig. 9) Remove the split pin from the clutch setting nut. (Fig. 10)

Unscrew the nut and remove the axial bearing. (Figs. 11 and 12)

Unscrew the 6 screws from the right-hand engine cover and separate the latter, together with the gasket, from the crankcase. Remove the washers used for setting the countershaft axial clearance. (Fig. 13)

Remove the countershaft with gears (Fig. 14), extract the clutch with discs and the needle bearing from the clutch housing.

Release the lock washer in the clutch housing. (Fig. 15)

Lock the clutch housing using the tool 730.159 and unscrew the left-hand thread nut. (Fig. 16)

Remove the clutch housing by applying light knocks with a wooden or plastic mallet. (Fig. 17)

Unscrew the 2 screws joining the crankcase halves on the outer edge. (Fig. 18)

Stand the engine upright, remove the spark plug and with the socket spanner 11 unscrew 4 nuts and remove the head with the gasket. (Fig. 19)

Remove the cylinder (Fig. 20) and the cylinder gasket.

Remove the piston pin circlips. (Fig. 21)

Push the pin outwards and remove the piston. (Fig. 22)

Turn the engine round to horizontal position, the magneto facing upwards. Use the tool 731.183 to lock the chain sprocket, unscrew the nut and remove the chain sprocket. (Fig. 23)

Use the tool 732.202 to lock the magneto flywheel and remove the flywheel nut. (Fig. 24)

With the CEV magneto, screw the tool 736.533 into the flywheel, and the tool 732.746 with the ISKRA-BOSCH magneto, and remove the flywheel. (Fig. 25)

Unscrew 3 screws and remove the magneto stator. (Fig. 26)

Unscrew the 7 screws joining the two crankcase halves.

Screw the tool 735.888 in place of the stator.

By applying light knocks with a wooden or plastic mallet to the joining edge of crankcase halves and slowly screwing down the screw on the tool 735.888, gradually press the crankshaft out of the left-hand crankcase. (Fig. 27)

When the crankcase halves are from 3 to 5 mm apart, turn the engine round on the stand, the tool 735.888 being positioned at the bottom, and proceed with screwing the screw on the tool until the crankshaft is pressed out of the left-hand crankcase. (Fig. 28).

The left-hand crankcase with gearbox gears is left on the stand. (Take care of the axial clearance adjusting washers in the gearbox!)

Knock out the crankshaft left in the right-hand crankcase as shown in Figure 29.

Remove the starter shaft assy. from the left-hand crankcase. (Fig. 30)

Remove the gearshift shaft along with the drive shaft. (Fig. 31)

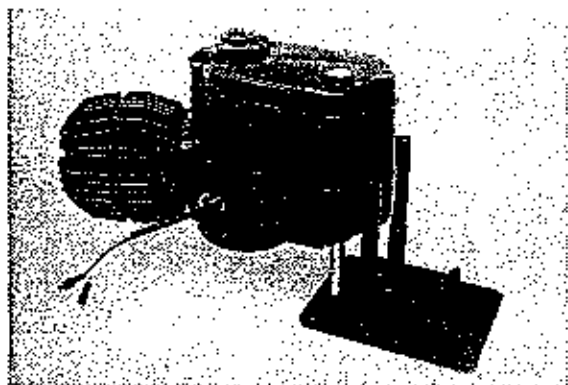

9

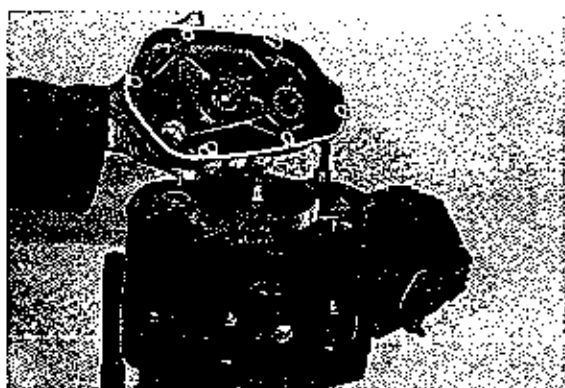

13

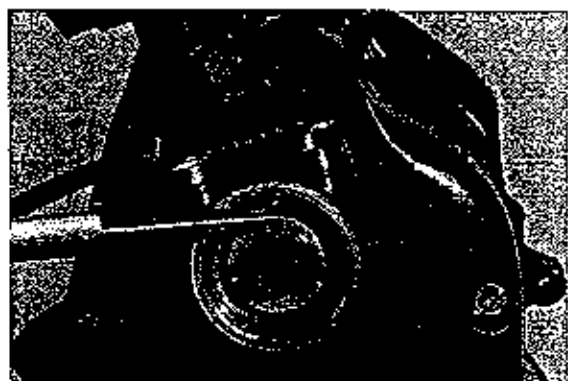

10



14

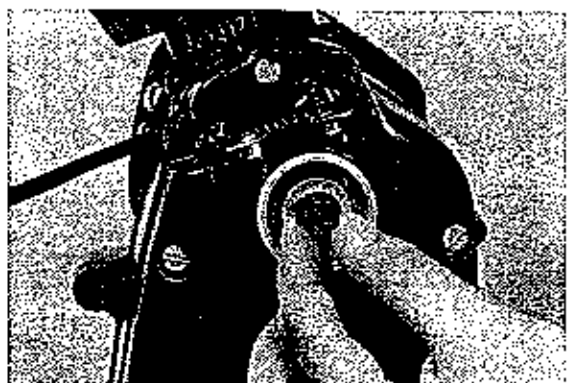

11

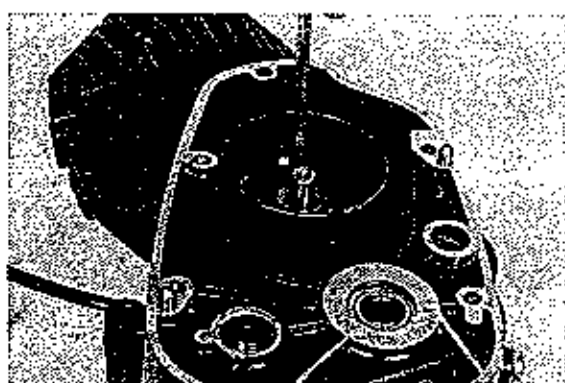

15

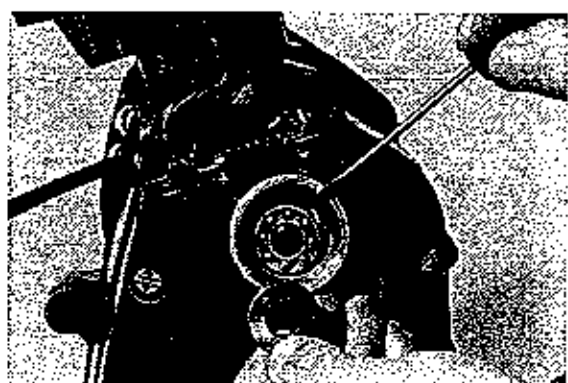

12



16

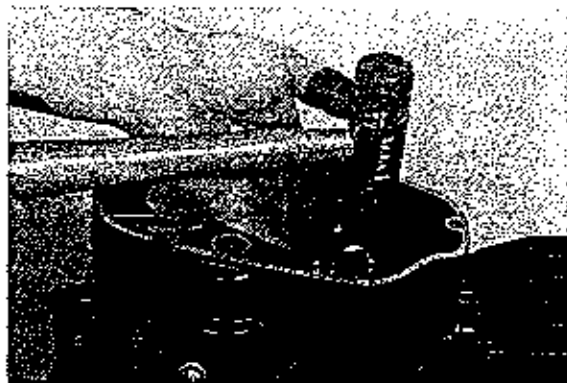

17

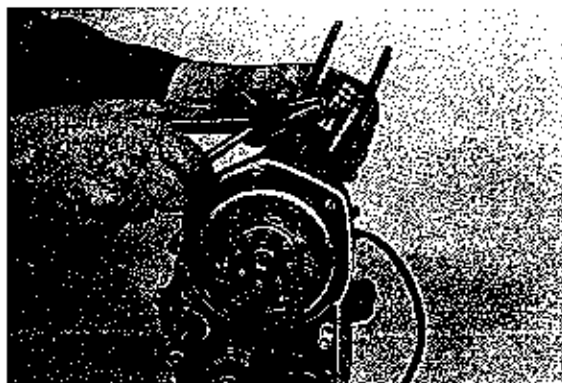

21

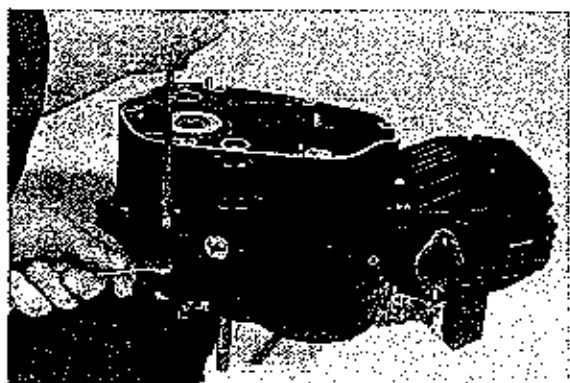

18

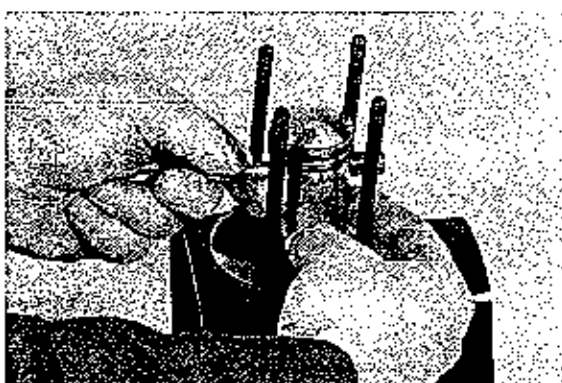

22



19

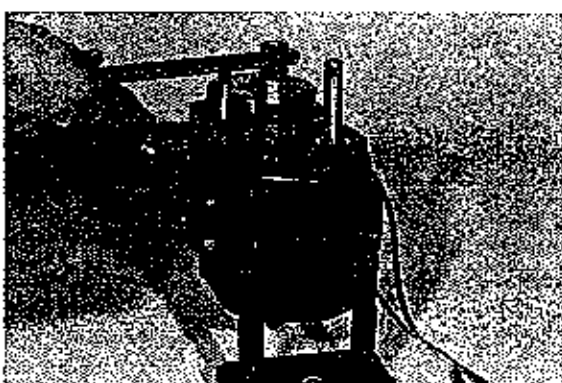

23

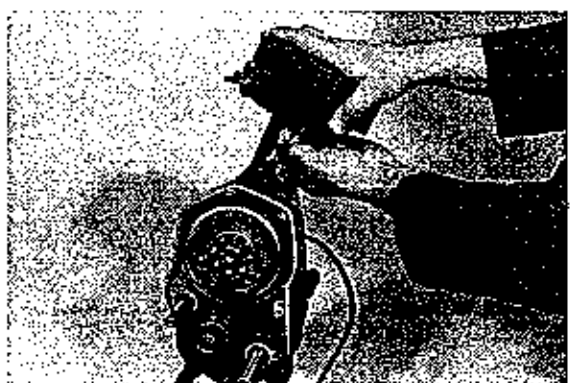

20

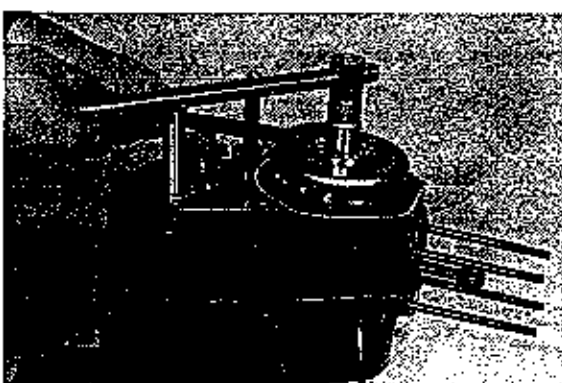

24

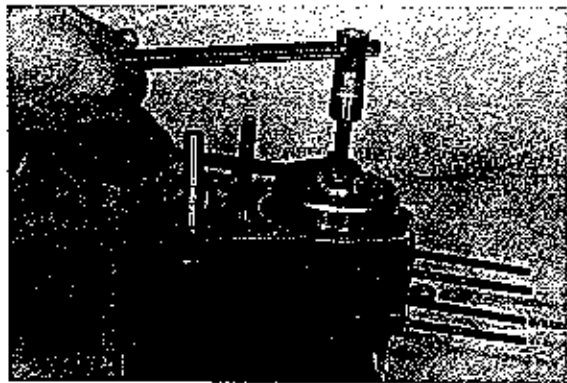

25

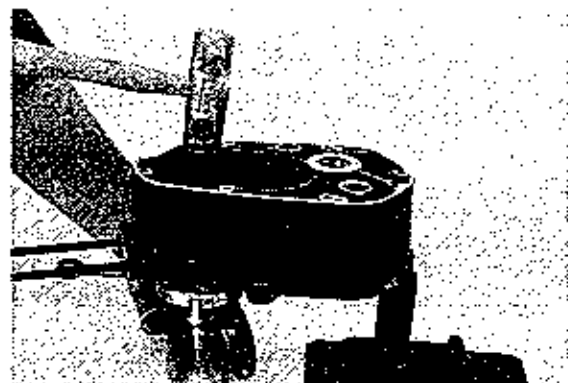

29

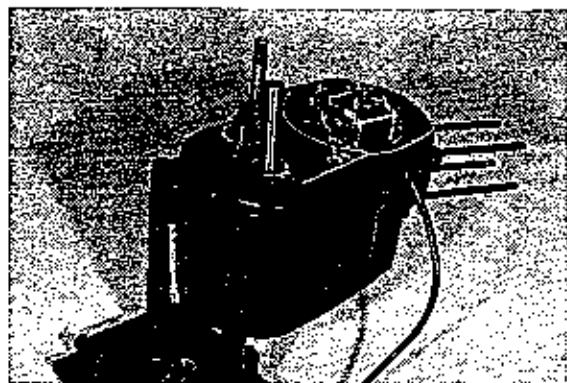

26

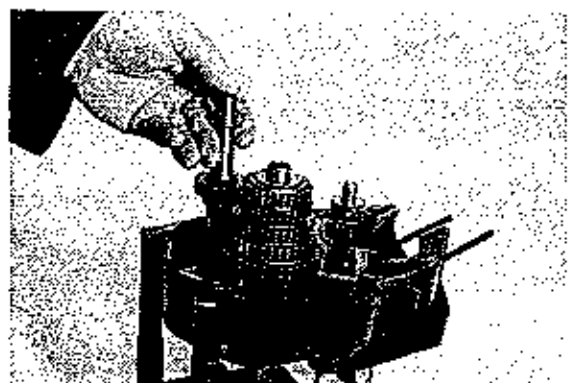

30

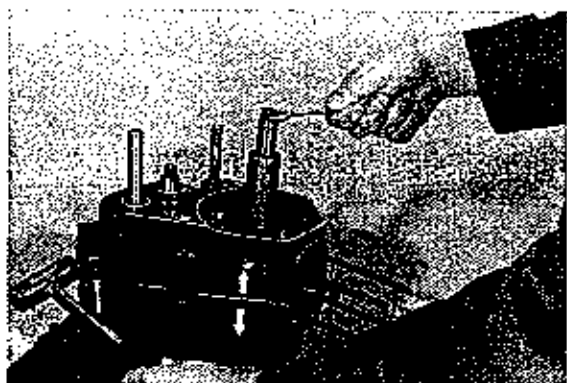

27

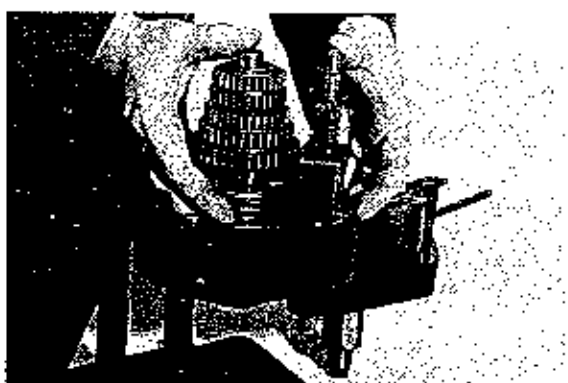

31

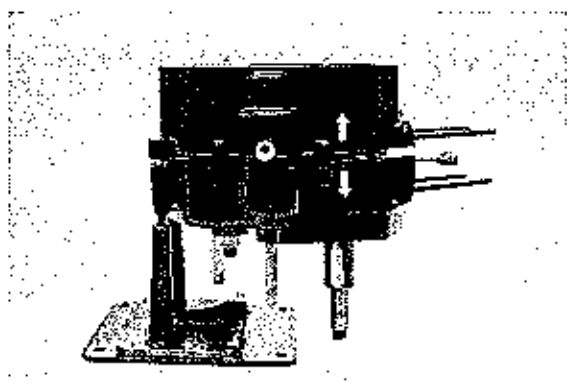

28

Najprej prekontrolirati, če polovici ohišja nista poškodovani ali deformirani.

Ravnino naležnih površin kontrolirati na tuširni plošči (sl. 32). Poškodovane površine po potrebi obdelati na tuširni plošči. Obdelava ohišja z brušenjem ali piljenjem ni dopuščena.

Tesnila in tesnilne obroče pregledati, če niso poškodovani. Poškodovana oljna tesnila nujno zamenjati (sl. 33).

Kontrolirati ležaje in če ugotovimo zračnost, jih je potrebno zamenjati.

Demontažo predležnega zobnika opraviti kot prikazuje slika (34).

Razstavljanje zobnikov III. in IV. prestave opraviti le tedaj, če je eden od zobnikov poškodovan ali če hoče imeti lastnik motornega kolesa drugačno število prestav. V tem ravnati po sliki (35).

Pretično gred (sl. 36) razstaviti takole:

- sneti distančne podložke
- sneti pretične vilice (sl. 37)
- z roko stisniti vzmet in sprostiti omejevalca (sl. 38).

First re check the crankcase halves for damage or distortion.

Check the gripping faces on the levelling plate (Fig. 32). If necessary, rectify the damaged surfaces on the levelling plate. Grinding or filing the crankcase is not allowed.

Check the gaskets and sealing rings for damage. Replace damaged oil seals without fail. (Fig. 33)

Check the bearings and replace them if clearance is established.

Remove the countershaft gear as shown in Figure 34. Dismantle the 3rd and 4th speed gears only when one of them is damaged or if the machine owner wants to have a different number of gears. If that is the case, refer to Figure 35.

The gearshift shaft (Fig. 36) is dismantled as follows:

Remove the distance washers.

Remove the selector fork. (Fig. 37)

Compress the spring with hand and release the two levers. (Fig. 38)



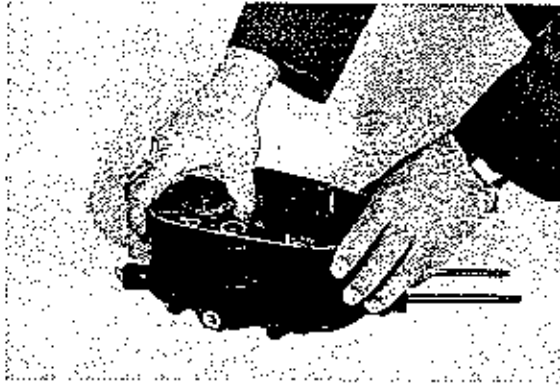

32

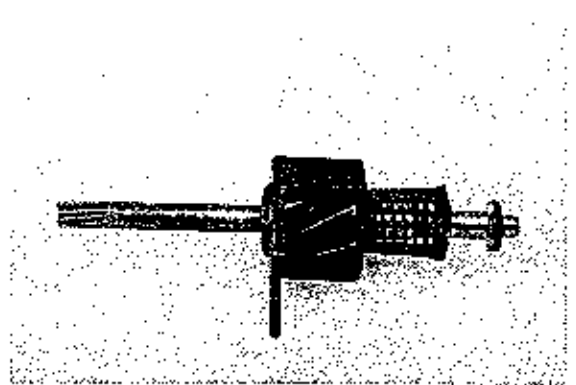

36

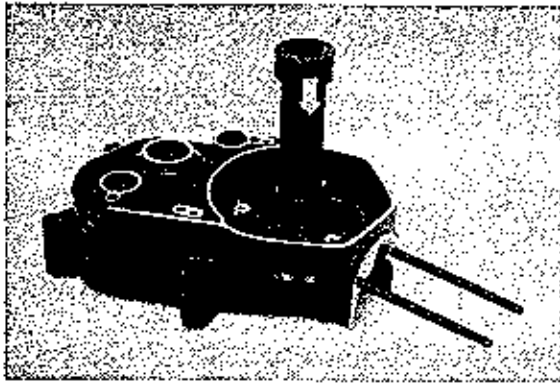

33

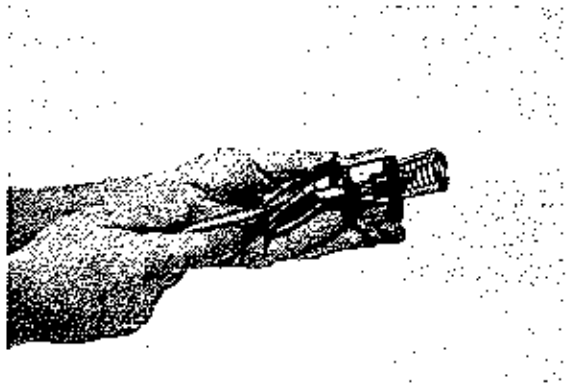

37

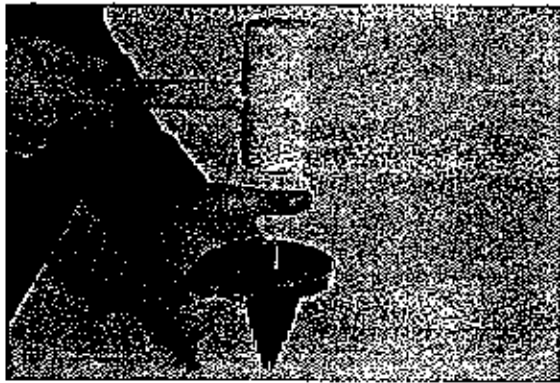

34

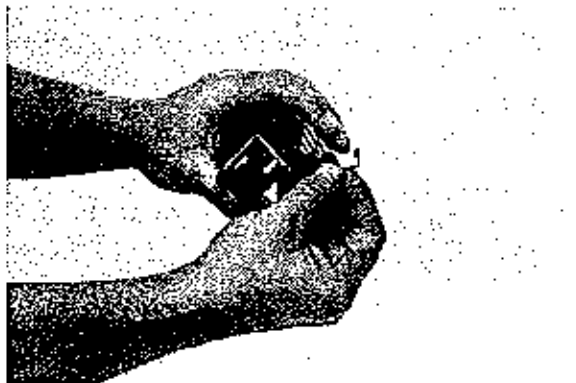

38

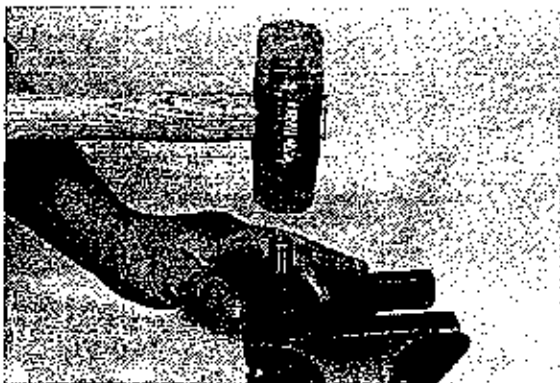

35

Gonilno gred (sl. 39) razstaviti takole:

- sneti regulirne podložke (sl. 40/a)
- z gredi sneti vse zobnike (sl. 40/b)
- z druge strani obe skodelici in vzmet (sl. 40/c)
- objemko potisniti v 5. prestavo tako, da izpadeta obe kroglici (sl. 41/a), ki premikata pretični trn v gredi
- sneti objemko (sl. 41/b) in štiri ploščice (sl. 41/c)
- sneti skodelici in vzmet (sl. 41/d)
- v primeru potrebe je moč iz notranjosti gredi demontirati tudi pretični trn, v katerega je vtisnjen klin z varovalnim zatičem za vključevanje posameznih prestav. Klin izbiti iz pretičnega trna (sl. 42) in trn izvleči (sl. 43), istočasno se sprost kroglica z vzmetjo
- pri montaži gonilne gredi je potrebno najprej vstaviti vzmet in kroglico v ustrezajočo odprtino pretičnega trna. Tako sestavljen trn poriniti v votli del gonilne gredi, pri tem paziti, da kroglica vskoči v prvo luknjo na gredi. Poriniti pretični trn v prvi naslednji položaj, vstaviti zatič in ga fiksirati z medeninaštim zatičem (sl. 44 in 45)
- na drugo stran gredi, k varovalnemu obroču namestiti obe skodelici z vzmetjo, ter položiti na odrezkani del gredi obe vodilni ploščici hkrati z dvema preluknjanimi ploščicama. Preko ploščic vstaviti objemko in v žleb vstaviti obe kroglici (sl. 46). Kroglici morata vskočiti v ustrezajoče kanale, ko objemko porinemo navzgor
- druge dele montirati popolnoma simetrično
- tako sestavljeno pretično gred preizkusiti s premikanjem objemke v obe smeri (vzmeti sta napeti — sl. 47), pri čemer mora pretični trn z lahkoto zavzemati vseh šest položajev.
- na gred postaviti zobnike. Paziti na pravilno postavitev zobnika prve in pete prestave. Zobniki morajo biti postavljeni tako, da je tudi med I. in II. prestavo ter IV. in V. mogoč prosti tek

The drive shaft (Fig. 39) is dismantled as follows:

- Remove the adjusting washers. (Fig. 40a)
- Remove all the gears from the shaft. (Fig. 40b)
- Remove both cups and spring from the other side. (Fig. 40c)
- Push the shackle into the 5th gear so as to make both balls, which move the shifter pin in the shaft, fly loose. (Fig. 41a)
- Remove the shackle (Fig. 41b) and 4 plates. (Fig. 41c)
- Remove the two cups and spring. (Fig. 41d)
- If necessary, the shifter pin with the impressed cotter, which includes the gearshift protective pin, can be removed too.
- Drive the cotter out of the shifter pin (Fig. 42) and extract the pin (Fig. 43), making the ball with spring fly loose.
- When fitting the drive shaft, you should first insert the spring and the ball into the appropriate shifter pin hole. Push the assembled pin into the hollow portion of the drive shaft, making sure the ball enters the first hole in the shaft. Move the shifter pin to the following position, insert the pin locking it with a brass pin. (Fig. 44 and 45)
- Fit both cups with spring by the protective ring on the other side of the shaft and place both guide plates, together with the two perforated plates, on the milled off portion of the shaft. Mount the shackle over the plates and insert both balls into the groove. (Fig. 46). The two balls should enter the appropriate channels when the shackle is pushed upwards.
- The other parts are installed symmetrically.
- The assembled gearshift shaft is tested by moving the shackle both ways, (the two springs being stretched — Fig. 47), the shifter pin should be easily moved to either of the six positions.
- Install the gears on the shaft, taking care the 1st and 5th speed gears are properly fitted; idling should also be possible between the 1st and 2nd, and the 4th and 5th gears.



39

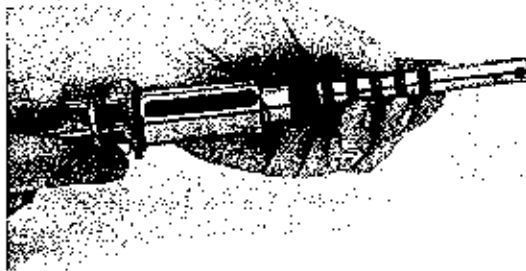

43

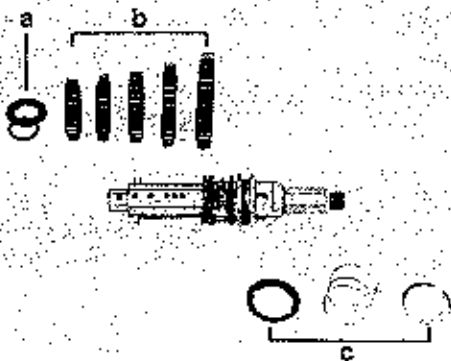

40



44

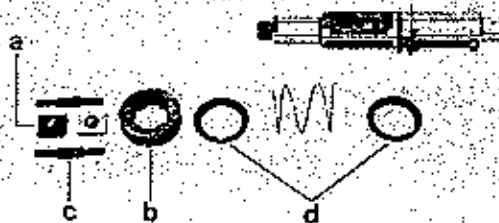

41



45

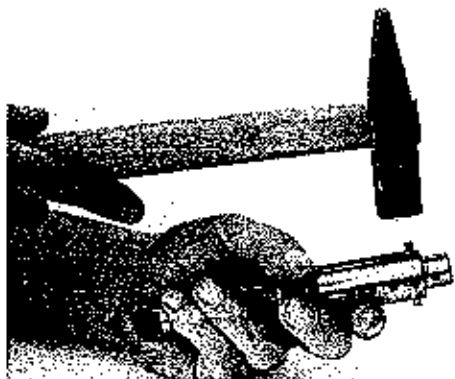

42

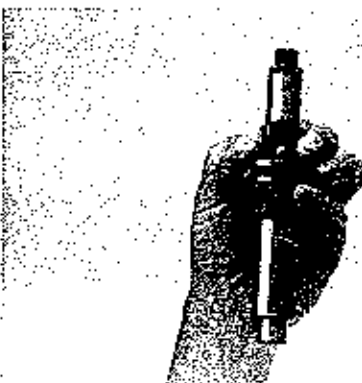

46

— pri menjalniku s štirimi prestavami je peti zobniški par nadomeščen s pušami (sl. 48).

Zagonsko gred razstaviti tako, da sprostimo vse dele na gredi (sl. 50):

- oporne podložke (sl. 50/a)
- distančno pušo (sl. 50/b)
- sojemalec z zavorno vzmetjo (sl. 50/c)
- zagonski zobnik demontiramo tako, da predhodno snamemo segerjev obroč, naletni obroček (sl. 51) in varovalni obroček.

Pogonsko gred z lamelami sklopke razstaviti s pomočjo dveh puš kat. št. 205.604, dveh podložk debeline ca. 0,5 mm in matice M 8 × 1. Matico priviti toliko, da se skodelice vzmeti približajo druga drugi (sl. 52)

- sneti varovalni obroč in lamele sklopke (sl. 53)
- pogonsko gred sklopke z obema skodelicama vpeti v primež ali klešče za pločevino (sl. 54) in odvití matico, da je moč izvleči zatič iz trna sklopke (sl. 55)
- z druge strani izvleči trn sklopke (sl. 56)
- demontirati vse dele sklopke (sl. 57)
- pregledati lamele ter vzmeti sklopke. V slučaju obrabe, pregretja ali mehanske poškodbe jih je potrebno zamenjati
- montažo sklopke izvršiti po obratnem vrstnem redu, pri tem paziti, da se skodelica z zareza (sedež zatiča) ujema z ustrežajočim žlebom na pogonskem zobniku
- pri montaži notranjih lamel paziti, da se bradavičasta izboklina ujema z vdolbino naslednje lamele
- bovden sklopke nastaviti z odvijanjem regulirnega vijaka tako, da dosežemo na ročici sklopke 2—3 mm prostega hoda

With a 4-speed gearbox, the 5th bevel gear has been replaced with bushes. (Fig. 48)

The starter shaft is dismantled by detaching all the items on the shaft, (Fig. 50):

- Retaining washers (Fig. 50a)
- Spacer (Fig. 50b)
- Driver with brake spring (Fig. 50c)

To remove the starter sprocket, first remove the Sg ring, the thrust ring (Fig. 51) and protective ring.

To remove the clutch driving gear, along with the discs, use two bushes 205.604, two washers of approx 2 mm in thickness, and a M8 × 1 nut. Screw on the nut so as to make the spring cups approach each other. (Fig. 52)

Remove the protective ring and the clutch discs. (Fig. 53)

Fix the clutch driving gear with both cups into a vice or sheet metal pliers (Fig. 54) and unscrew the nut to allow the pin to be extracted from the clutch pin. (Fig. 55)

Extract the clutch pin from the other side. (Fig. 56)

Remove all the clutch parts. (Fig. 57)

Check the clutch discs and springs. In case of wear, overheating or mechanical damage they should be replaced.

The clutch is assembled in the reverse of the removal sequence, making sure the cup with the two notches (the pin seat) fits into the appropriate groove on the clutch driving gear.

When fitting the interior discs, make sure the nipple bulge fits into the next disc recess.

Adjust the clutch control cable by unscrewing the adjusting screw to get of from 2 to 3 mm free play.

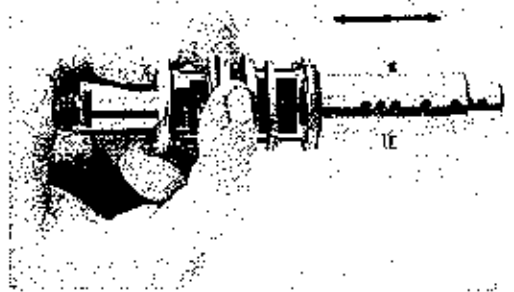

47

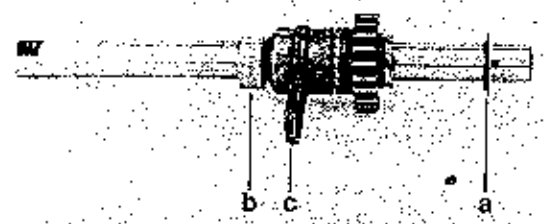

50

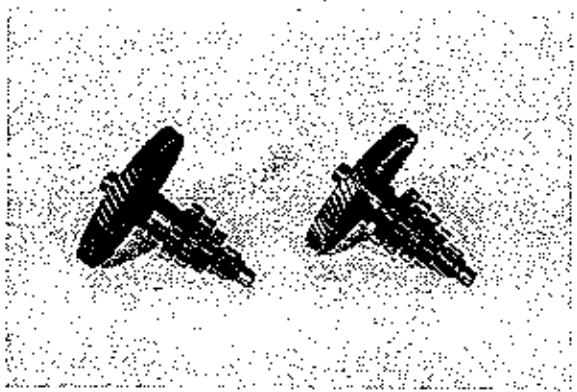

48

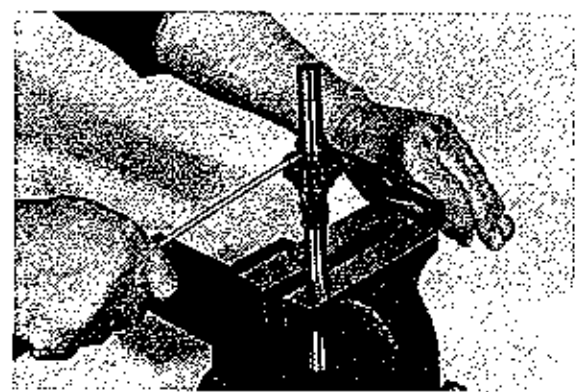

51

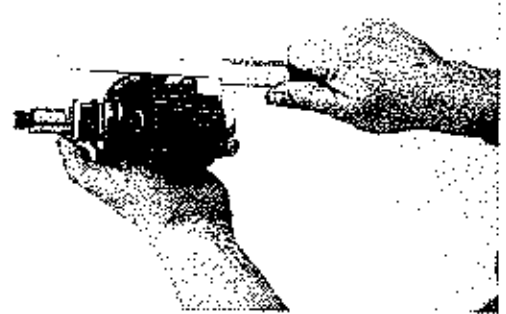

49

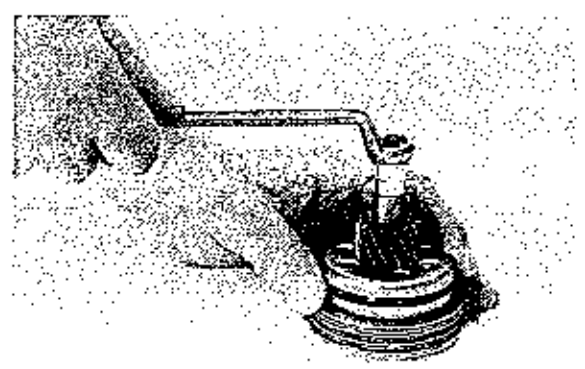

52

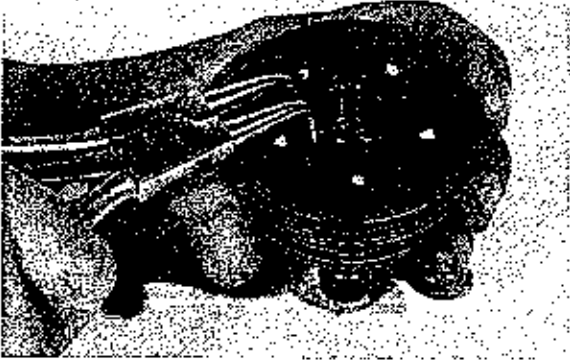

53

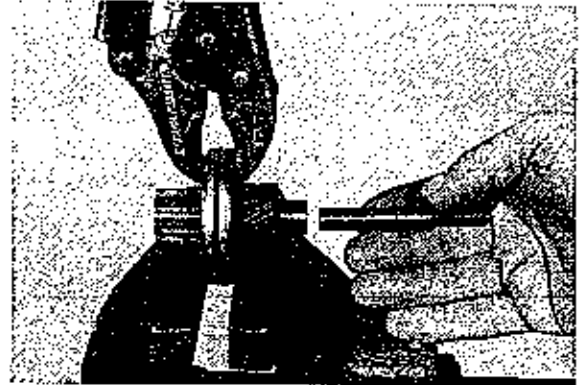

56

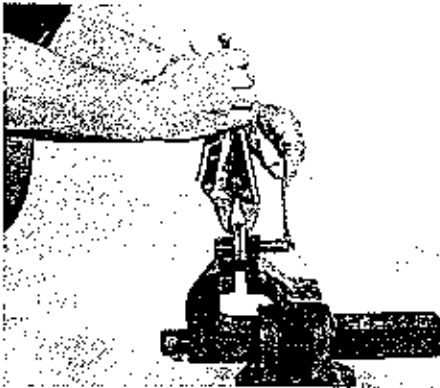

54

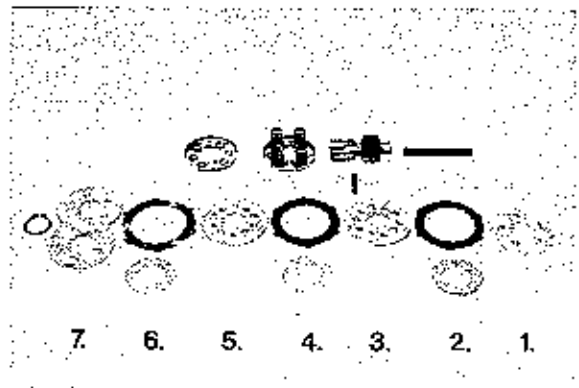

57

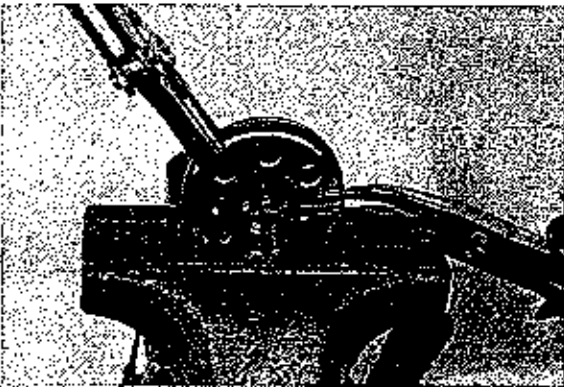

55

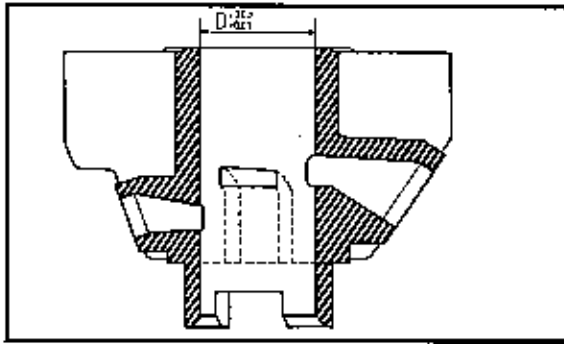

Valj in bat  
Cylinder and piston

D (mm)	
A	B
38,01 <sup>+0,01</sup>	38,02 <sup>+0,01</sup>

D1 D max 0,012mm  
Dovoljena ovalnost — 0,006 mm  
D1 D max 0,012 mm  
Allowable ovality 0,006 mm

	d 1	d 2	d 3	d 4
a	37,95 <sup>+0,01</sup>	37,91 <sup>+0,01</sup>	37,86 <sup>+0,02</sup>	37,84 <sup>+0,02</sup>
b	37,95 <sup>+0,01</sup>	37,92 <sup>-0,01</sup>	37,87 <sup>+0,02</sup>	37,85 <sup>+0,02</sup>

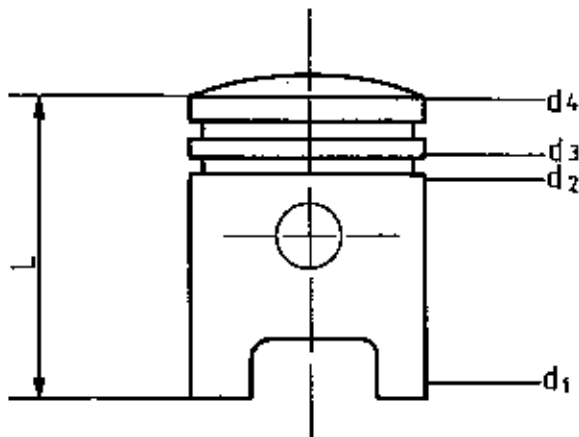

L = 50 mm, 55 mm  
Bat l. nadmera — Ø 38,50 mm  
Piston 1st oversize — Ø 38,50 mm  
Valj se brusi po tabeli:  
The following table is used to rebore the cylinder:

D	
A	B
38,51 <sup>+0,01</sup>	38,52 <sup>+0,01</sup>

## Motorna gred

- v slučaju, da ležaja ostaneta na motorni gredi, sneti ju z orodjem 731.155 (sl. 58)
- kontrolo gredi opraviti med konicami kontrolne naprave in izmeriti opletanje na nakazanih točkah na sl. (59)
- dovoljeno opletanje na točkah 1 in 4 je 0,01 mm, na točkah 2 in 3 pa 0,02 mm
- kontrolirati navoja na obeh poloseh, izvrtino za zatič ter konični del gredi
- v primeru obrabe, zamenjati ojnično pušo s specialnim orodjem 716.714 (sl. 60)
- novo pušo vtisniti z istim orodjem, izvrtati izvrtino za mazanje batnega sornika ter s svedrom in pomičnim povrtalom povečati njen notranji premer na

$\varnothing 10 + 0,02$      $\varnothing 12 + 0,02$  mm  
+ 0,01            + 0,01 mm

## Crankshaft

- When the two bearings have been left on the crankshaft, they should be removed with the tool 731.155. (Fig. 58)
- Check the crankshaft between the gauge points and measure deflection at the points as indicated in Figure 59.
- The allowable deflection is 0.01 mm on points 1 and 4, and 0.02 mm on points 2 and 3.
- Check the thread on both semi-axes, the pin hole and the crankshaft conical portion. In case of wear, replace the connecting rod bush with the special tool 716.714. (Fig. 60)
- Emboss a new bush using the same tool, drill a piston pin oiling hole and ream its internal diameter with a drill and a sliding reamer to the following dimensions:

$\varnothing 10 + 0,02$      $\varnothing 12 + 0,02$  mm  
+ 0,01            + 0,01 mm



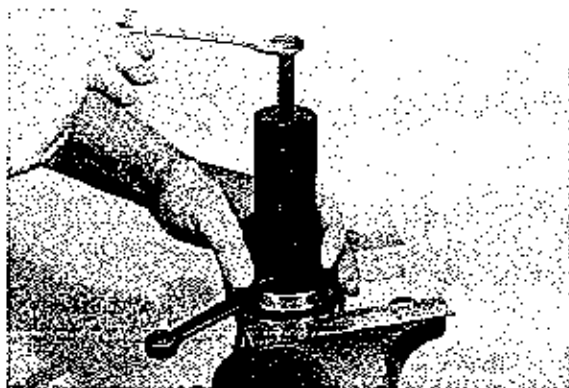

58

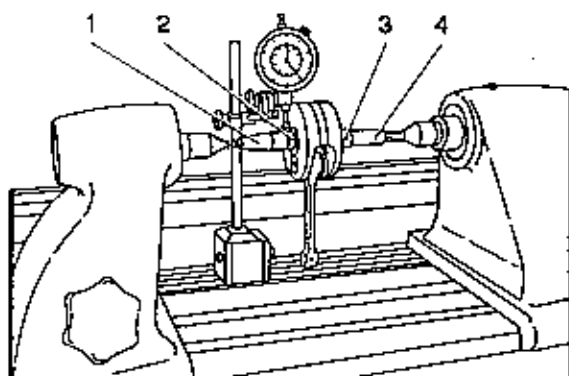

59



60

### Sestavljanje motorja

- ležaja motorne gredi vtisniti v ohišje (sl. 61)
  - motorno gred montirati v desno polovico ohišja. Deformacijo motorne gredi preprečiti z vlaganjem orodja 735.753 (sl. 62)
  - pri zamenjavi ohišja ali katere od ostalih gredi, s primerjanjem nastaviti aksialno zračnost, ki mora znašati 0,1—0,3 mm (sl. 49)
  - v levo polovico ohišja vstaviti gonilno gred komplet s pretično gredjo in zagonsko gred
  - postaviti tesnilo ohišja in desno polovico ohišja z motorno gredjo
  - obrniti motor na stojalu
  - s privijanjem matice na orodju št. 735.888 in rahlimi udarci lesenega ali plastičnega kladiva sestaviti ohišja (sl. 63)
  - z vrtenjem vseh gredi preveriti brezhibnost sestavljanja
  - pri montaži valja naoljiti bat in pazljivo izvršiti montažo
  - pri tem paziti na položaj batnih obročkov in oznake na batu (puščica), ki mora biti obrnjena proti izpušnemu kanalu valja
  - montirati magnetni vžigalnik
- V motor naliti 400 cm<sup>3</sup> olja SAE 30 skozi odprtino merilne palice.

### Momenti pritegovanja matic in vijakov

- |                                    |               |
|------------------------------------|---------------|
| — vijaki ohišja in pokrova motorja | M6 — 10 Nm    |
| — matice glave valja               | M7 — 12-15 Nm |
| — matica magneta                   | — 30 Nm       |
| — matica sklopke                   | — 30 Nm       |
| — matica verižnega kolesa          | — 35 Nm       |
| — pritrdilni vijaki motorja        | — 20-25 Nm    |

### ORODJE

- izvijač
- ključi 10, 11, 13, 19, 22, 30
- kleščice
- kleščice za zunanje varovalke
- kleščice za notranje varovalke
- kladivo 400 gr.
- leseno (plastično) kladivo
- podstavek 714.011
- snemalec vztrajnika 736.533
- ključ za blokiranje vztrajnika 732.202
- puša 702.856
- pripomoček Ø 10 — 708.253
- pripomoček Ø 12 — 716.714
- ključ za blokiranje sklopke 730.159
- ključ za blokiranje verižnika 731.183
- merilna ura 975.709
- podaljšek 011.008
- priprava za razstavljanje ohišja 735.888
- vilice 735.753

### Re-assembling the engine

- Emboss the two crankshaft bearings into the crankcase. (Fig. 61)
- Install the crankshaft into the right-hand crankcase. Obviate a possible distortion of the crankshaft by inserting the tool 735.753. (Fig. 62)
- When replacing the crankcase or any of the other shafts, set the axial clearance by comparing the respective figures and it should amount to of from 0.1 to 0.3 mm. (Fig. 49)
- Insert the driving gear assy. with the gearshift shaft and the starter shaft into the left-hand crankcase. Install the crankcase gasket and the right-hand crankcase with the crankshaft.
- Turn the engine round on the stand.
- Assemble the right- and left-hand crankcase halves by screwing down the nut on the tool 735.888 and by applying light knocks with a wooden or a plastic mallet. (Fig. 63)
- By rotating all the shafts, make sure they have been properly assembled.
- Carefully install the cylinder and oil the piston.
- Pay attention to position of the piston rings and to the arrow on the piston which should face the cylinder exhaust channel.
- Install the magneto.
- Pour 400 cc SAE oil into the engine through the dipstick opening.

### Torque settings of nuts and screws

- |                                   |    |               |
|-----------------------------------|----|---------------|
| Crankcase and engine cover screws | M6 | 1.0 kgf m     |
| Cylinder head nuts                | M7 | 1.2-1.5 kgf m |
| Magneto nuts                      |    | 3.0 kgf m     |
| Clutch nut                        |    | 3.0 kgf m     |
| Chain sprocket nut                |    | 3.5 kgf m     |
| Engine fixing screws              |    | 2.0-2.5 kgf m |

### TOOLS

- Screwdriver
- Spanners 10, 11, 13, 19, 22, 30
- Pliers
- External circlip pliers
- Internal circlip pliers
- Hammer 400 gr
- Wooden or plastic mallet
- Stand 714.011
- Flywheel extractor 736.533
- Flywheel locking spanner 732.202
- Bush 702.856
- Accessory Ø 10 — 708.253
- Accessory Ø 12 — 716.714
- Clutch locking spanner 730.159
- Chain sprocket locking spanner 731.183
- Dial gauge 975.709
- Extension 011.008
- Crankcase dismantling device 735.888
- Fork 735.753



61

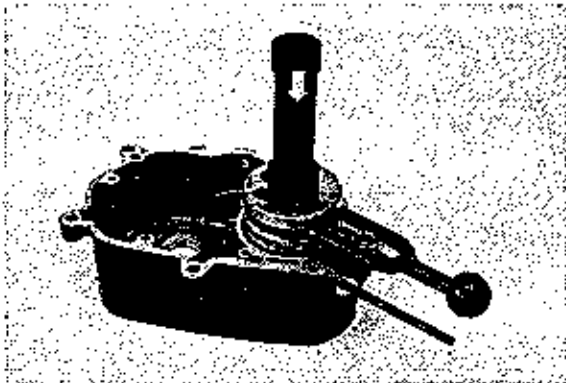

62

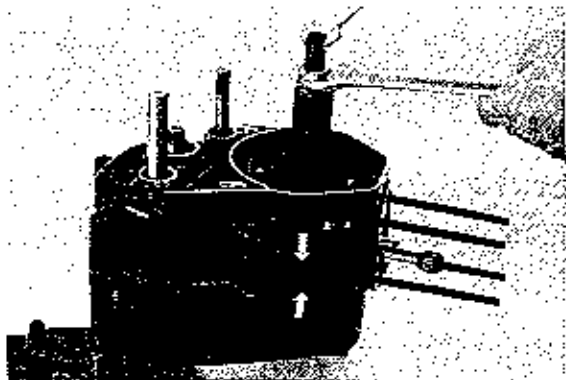

63

## VŽIGALNIK

- CEV — kontaktni model 100641 100 —  
50 W/12 V (sl. 64)
- ISKRA — kontaktni model AVJ 1207 —  
50 W/12 V (sl. 64)
- ISKRA — brezkontaktni model AVJ 5106 —  
90 W/12 V (sl. 65)

Razdalja med kontaktoma prekinjevalnika  
0,35—0,45 mm

## SVEČKE

- BOSNA F 75
  - BOSCH W 5 AC T1 za modele od 1,09—1,3 kW
  - MARELLI CV 225
  - BOSNA F 80
  - BOSCH W 4 AC za modele od 1,60 kW
  - BOSNA F 100
  - BOSCH W 3 AC za modele od 4 kW
- Razdalja elektrod — 0,5 mm

## ŽAROMET

- štirioglat »E«  
glavna žarnica — 12 V 15 W ali  
glavna žarnica — 12 V 25/25 W ali  
glavna žarnica — 12 V 45 W/40 W
- pozicijska — 12 V 3 W
- pozicijska — 12 V 5 W
- pozicijska — 12 V 15 W

## ZADNJA LUČ

- žarnica — 12 V 4 W, 12 V 5 W
- žarnica STOP — 12 V 10 W, 12 V 15 W

**Opomba:** Točno moč žarnic določiti po katalogu rezervnih delov za model, ki ga servisirate

## SMERNIKI

- Žarnice — 12 V 10 W

## KONTROLNA SIGNALIZACIJA IN OSVETLITEV INSTRUMENTOV

- Žarnice — 12 V 1,2 W

## STIKALA

- CEV — montirana na krmilu

## MAGNETO

- Type: CEV, contact breaker model 100641  
100-50 W/12 V (Fig. 64)
- ISKRA, contact breaker model AVJ 1207 —  
50 W/12 V (Fig. 64)
- ISKRA, breakerless model AVJ 5106 —  
90 W/12 V (Fig. 65)

Contact breaker points gap:  
0.35-0.45 mm

## SPARK PLUGS

- Type: BOSNA F 75 for models of from  
BOSCH W 5 AC T1 1.09-1.3 kW  
MARELLI CV 225
- BOSNA F 80 for models of 1.60 kW  
BOSCH W 4 AC  
BOSNA F 100 for models of 4 kW  
BOSCH W 3 AC

Electrodes gap 0.5 mm

## HEADLAMP

- Type: Square »E«
- Main bulb: 12 V 15 W, or  
12 V 25/25 W or  
12 V 45 W/40 W
- Position bulb: 12 V 3 W, or  
12 V 5 W, or  
12 V 15 W

## TAIL LAMP

- Bulb: 12 V 4 W, 12 V 5 W  
Stop bulb: 12 V 10 W, 12 V 15 W  
Note: The exact bulb rating for the model under repair to be defined under the Spares Catalogue

## DIRECTION INDICATORS

Bulbs 12 V 10 W

## WARNING LIGHTS AND ILLUMINATION OF INSTRUMENTS

Bulbs 12 V 1.2 W

## SWITCHES

CEV — Fitted on the handlebar

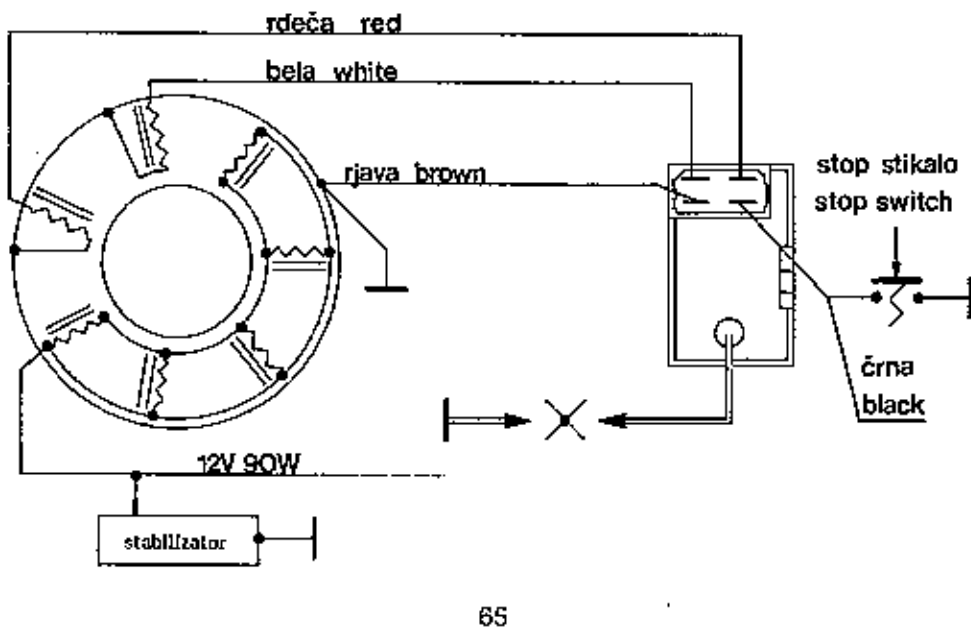
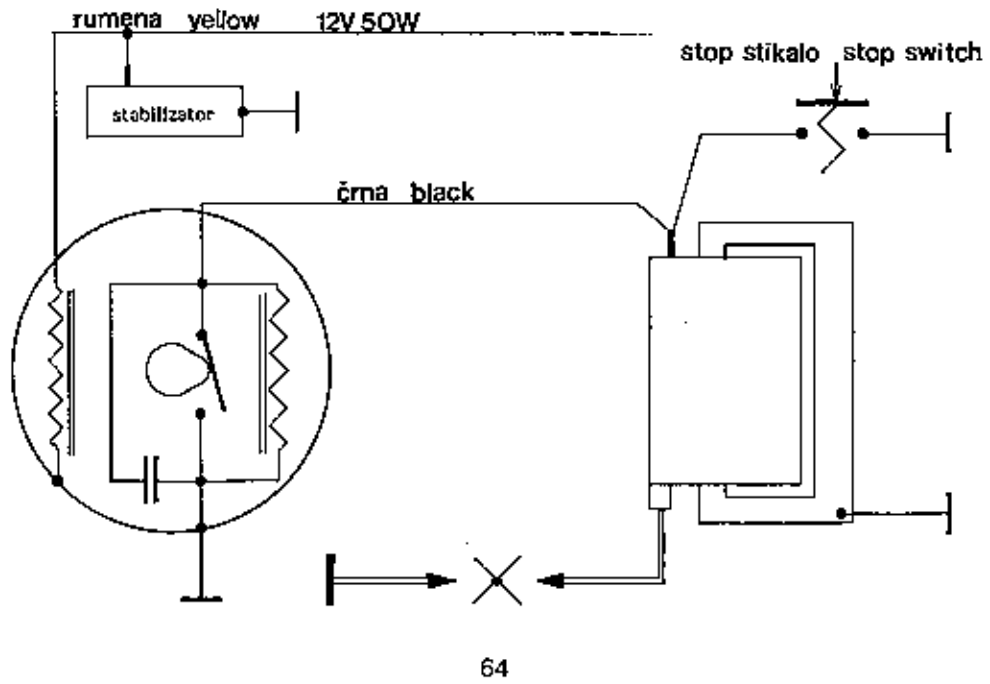

**Nastavitev predvžiga — kontaktni vžigalnik**

- odviti svečko ter na njeno mesto viti specialno pripravo 732.193 z merilno uro in podaljškom merilne ure 011.008.
- preveriti in po potrebi nastaviti razmak kontaktov prekinjevalca, ki mora znašati 0,35—0,45 mm (sl. 66).
- za kontrolo trenutka odpiranja kontaktov prekinjevalca uporabiti kontrolnik z zvočno signalizacijo, ali kako drugo indikacijo, svetlobno ali omsko ( $\Omega$ ). En izvod kontrolnika vezati na ohišje motorja, drugega pa na črni prevodnik.
- ročno vrteti magnetni vztrajnik v smeri vrtenja motorja in (oznaka na mag. vztrajniku) paziti na trenutek, ko kontrolnik registrira odpiranje kontaktov.

Od tedaj naprej zasledujemo na merilni napravi za koliko milimetrov ali desetink milimetra bat še izrine podaljšek merilne ure do G.M.T.

Predvžig mora znašati  $1,8^{±0,1}$  mm pred G.M.T. (sl. 67)

Če ugotovimo, da je predvžig prevelik, popustimo vijake nosilne plošče in ploščo zasučemo v smeri vrtenja motorja. Privijemo vijake in ponovimo kontrolo. Pri premajhnem predvžigu pa nosilno ploščo magneta zasučemo proti smeri vrtenja motorja.

Predvžig nastaviti pri vsakokratni demontaži motorja.

**Kombinirana kontrola odmika in trenutka vžiga**

Odmik je točno določena vrednost, od katere je odvisna vžigalna napetost oziroma jakost iskre na svečki. To je pravzaprav razdalja med robom polovega čevlja vžigalne tuljave in odmikajočim se robom pola magneta v trenutku odpiranja kontakta in mora biti v mejah od  $12 ± 2$  mm. Odmično razdaljo meriti v trenutku, ko kontrolnik menja jakost svetlobe (frekvenco zvoka) sl. 67.

Trenutka vžiga ne nastavlja s kontaktno razdaljo. Za nastavitev so v nosilni plošči predvidene podolgovate pritrdilne odprtine. Odmik in razdaljo pletin kontrolirati vsakih 6000 km, ker se razdalja spreminja z obrabo odmičaka in odmičnega nosu v magnetnem vztrajniku.

Premajhen ali prevelik odmik se občutno opazi zlasti pri počasni vožnji s prižganimi lučmi, ko komaj zadostno vžigalno energijo oslabimo še s povratnim delovanjem navitja za luč.

**Ignition advance timing — Contact breaker**

Unscrew the spark plug and in its place screw in the special tool 732.193 with the dial gauge and extension 011.008.

Check and, if necessary, set the contact breaker points gap which should be 0.35-0.45 mm. (Fig. 66) To check the opening moment of the contact breaker points, use an audible warning gauge or some other illuminated or ohmic ( $\Omega$ ) indicator. Connect the output lead of the gauge to the crankcase and the other to the black lead.

Rotate the magneto flywheel by hand in the direction of engine rotation, noting carefully the moment of the points opening registered by the gauge. (See the mark on the magneto flywheel)

From then on observe the gauge for the distance to TDC, registered in millimeters or tenths of millimeters, by which the dial gauge extension is displaced by the piston.

The ignition advance should amount to  $1.8 ± 0.1$  mm BTDC. (Fig. 67)

If the ignition advance is found to be excessive, slacken the bearing plate screws and rotate the plate in the direction of engine rotation. Screw on the screws and re-check.

If, on the other hand, the ignition advance is found to be insufficient, turn the bearing plate in the opposite direction of engine rotation.

The ignition advance timing should be effected each time the engine is dismantled.

**Combined checking of the withdrawal and ignition point**

The withdrawal is a strictly determined value on which ignition voltage or spark strength depends. As a matter of fact, it is the distance between the ignition coil pole claw and the receding magnet pole edge in the moment the points open and it should be within the range of  $12 ± 2$  mm. The withdrawal distance should be measured in the instant the gauge alters the light intensity or sound frequency. (Fig. 67)

Do not set the ignition point with the points gap. To this purpose are provided the oblong fixing openings. Check the withdrawal and the points gap every 6000 kilometers as the gap varies according to wear of the cam and cam nose in the magneto flywheel.

An insufficient or excessive withdrawal distance is noticed primarily at slow speeds with the lights on when a barely sufficient ignition power is being further reduced by the return action of the light winding.

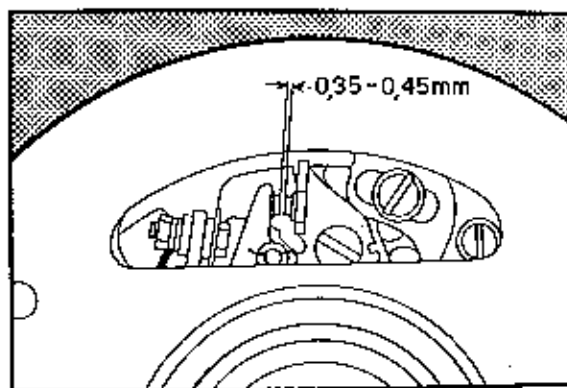

66

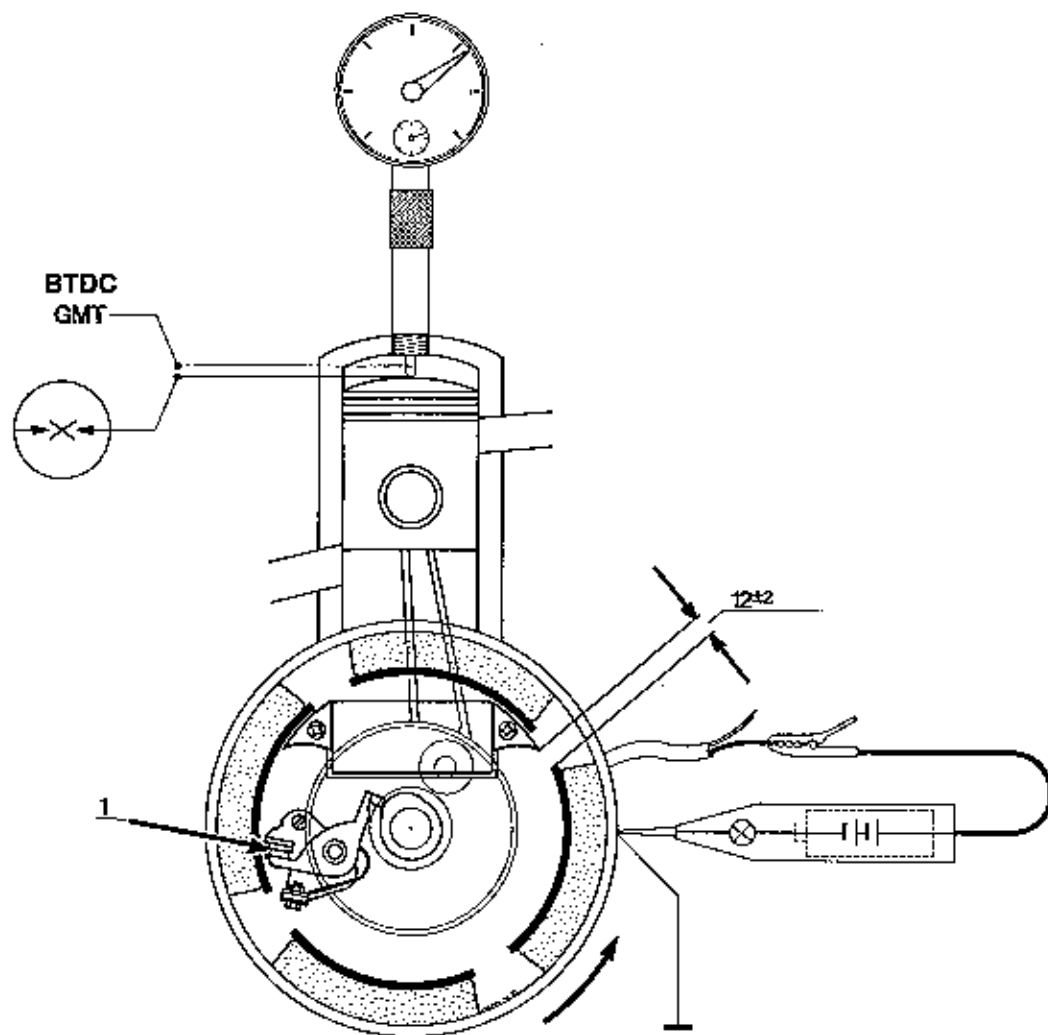

67

### Nastavitev vžiga — brezkontaktni vžigalnik

- Odviti svečko ter na njeno mesto uviti specialno pripravo 732.193 z merilno uro in podaljškom merilne ure 011.008.
- Z vrtenjem magnetnega vztrajnika postaviti bat v zgornjo mrtvo točko in postaviti skalo merilne ure v položaj 0.
- S sukanjem magnetnega vztrajnika v obratni smeri od vrtenja motorja postavimo vztrajnik v točko vžiga, kar odčitamo na merilni uri kot pomik bata za predpisano vrednost:  $0.8 \pm 0,25$  mm za BT 50.
- Ko je vztrajnik v poziciji vžiga, statorsko ploščo zasučemo tako, da se oznaka na prožilni tuljavi ujema z oznakami na magnetnem vztrajniku in statorsko ploščo privijemo.
- Po privijanju še enkrat preverimo točnost nastavitve (sl. 68).

### LEGENDA (za sl. 69)

1. Magnetni vžigalnik
2. Stabilizator napetosti
3. Stikalo luči
4. Stikalo STOP luči
5. Stikalo sirene
6. Sirena
7. Rele
8. Stikalo smernih kazalcev
9. Žarnice smernih kazalcev
10. Žarnice za razsvetljavo in označevanje vozila
11. Stop žarnica
12. Vžigalna tuljava
13. Stikalo za prekinitev delovanja motorja

### LEGENDA (za sl. 70)

1. Žaromet
2. Obratomer
3. Merilnik hitrosti
4. Kontrolna žarnica
5. Sirena
6. Stikalo — desno
7. Stikalo — levo
8. Vžigalna tuljava
9. Vžigalnik
10. Rele smerokaza

### Ignition timing — Breakerless magneto

Unscrew the spark plug and in its place screw in the special tool 732.193 with the dial gauge and dial gauge extension 011.008.

By rotating the magneto flywheel, set the piston to the TDC and set the dial gauge scale to position 0.

By rotating the magneto flywheel in the opposite direction of engine rotation, set the flywheel to the ignition point which is registered by the dial gauge as the piston travel for the prescribed value:

$0.8 \pm 0.25$  mm with the BT 50.

When the flywheel is at the ignition point, turn the stator plate so as to make the mark on the trigger coil coincide with the marks on the magneto flywheel and screw on the stator plate.

After screwing on, re-check the setting for accuracy. (Fig. 68)

### KEY TO THE FIGURE 69

- 1 Magneto
- 2 Voltage stabilizing tube
- 3 Light switch
- 4 STOP light switch
- 5 Horn switch
- 6 Horn
- 7 Relay
- 8 Direction indicators switch
- 9 Direction indicators bulbs
- 10 Warning and illuminating bulbs
- 11 Stop bulb
- 12 Ignition coil
- 13 Ignition cutoff switch

### KEY TO THE FIGURE 70

- 1 Headlamp
- 2 Revolution counter
- 3 Speedometer
- 4 Pilot bulb
- 5 Horn
- 6 Switch — RH
- 7 Switch — LH
- 8 Ignition coil
- 9 Magneto
- 10 Direction indicator relay
- 11 Voltage stabilizing tube
- 12 Stop switch
- 13 Tail lamp
- 14 Direction indicators

### KEY TO COLOURS:

- |                 |                |
|-----------------|----------------|
| Bela — White    | Zelena — Green |
| Rumena — Yellow | Rjava — Brown  |
| Plava — Blue    | Črna — Black   |
| Siva — Grey     | Rdeča — Red    |



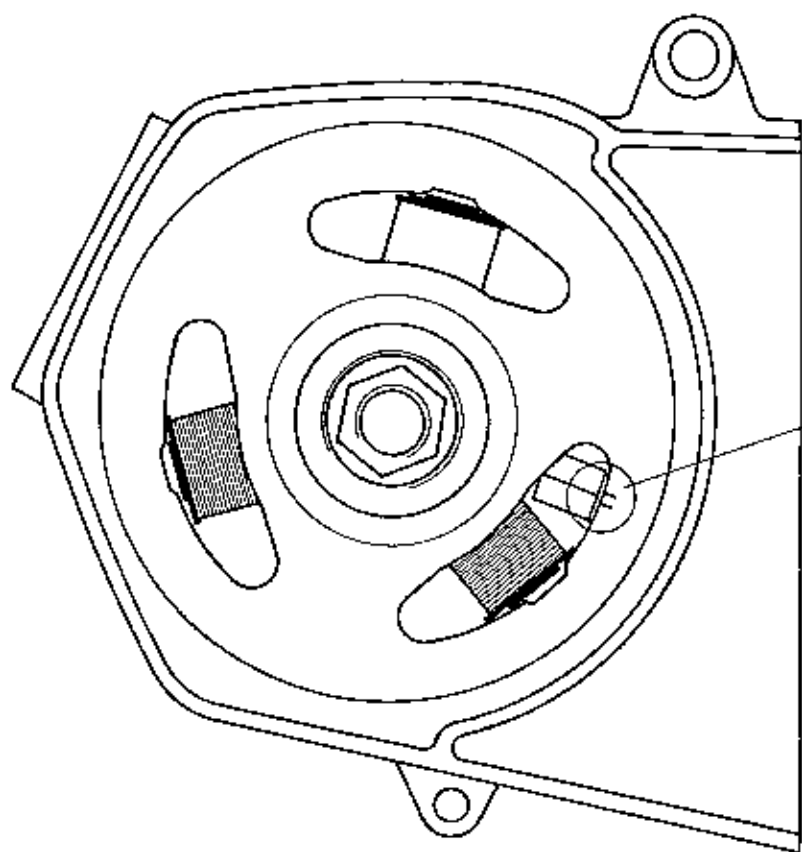

točka vžiga  
 $0,8 \pm 0,25$  pred GMT

ignition point  
 $0,8 \pm 0,25$  BTDC

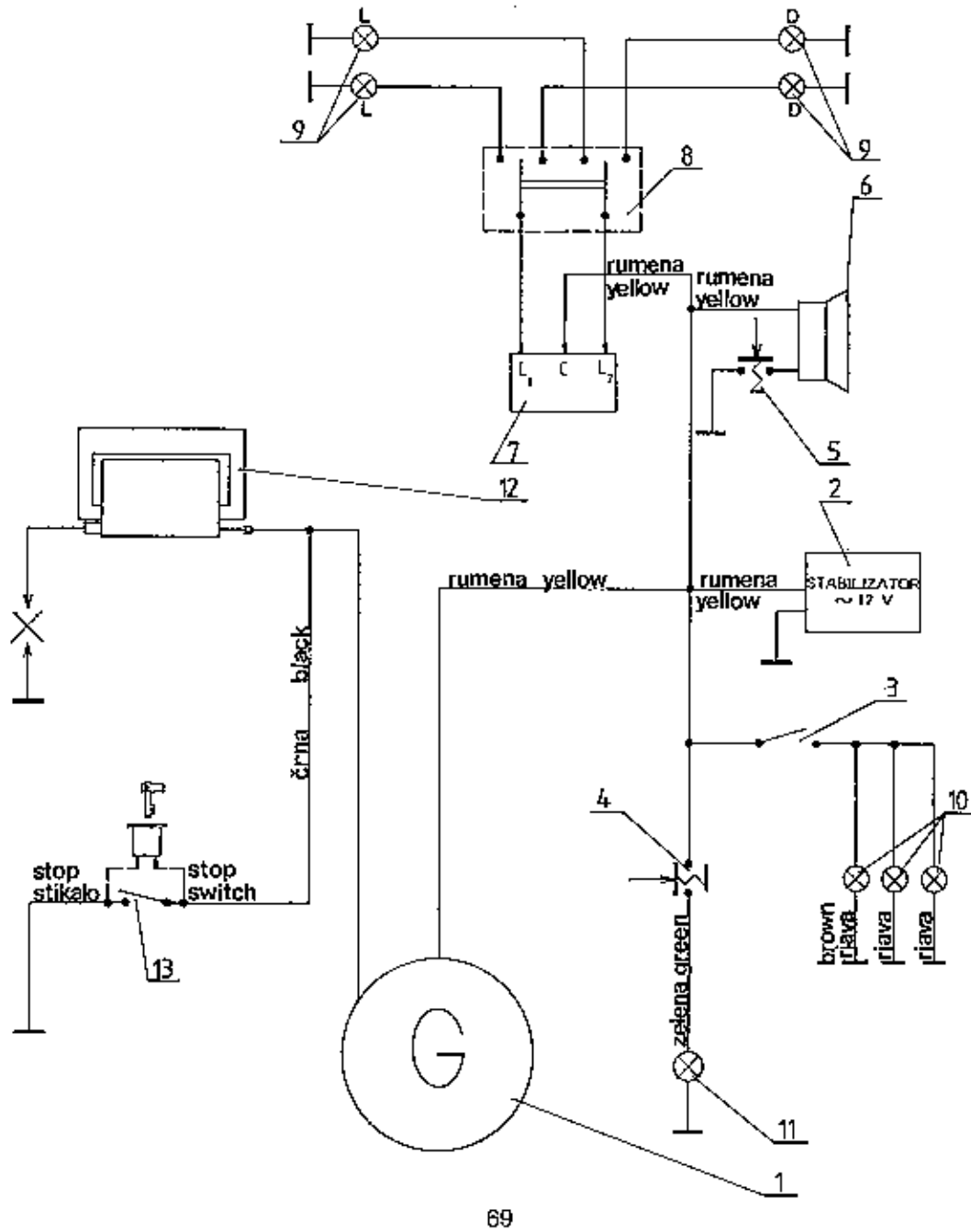

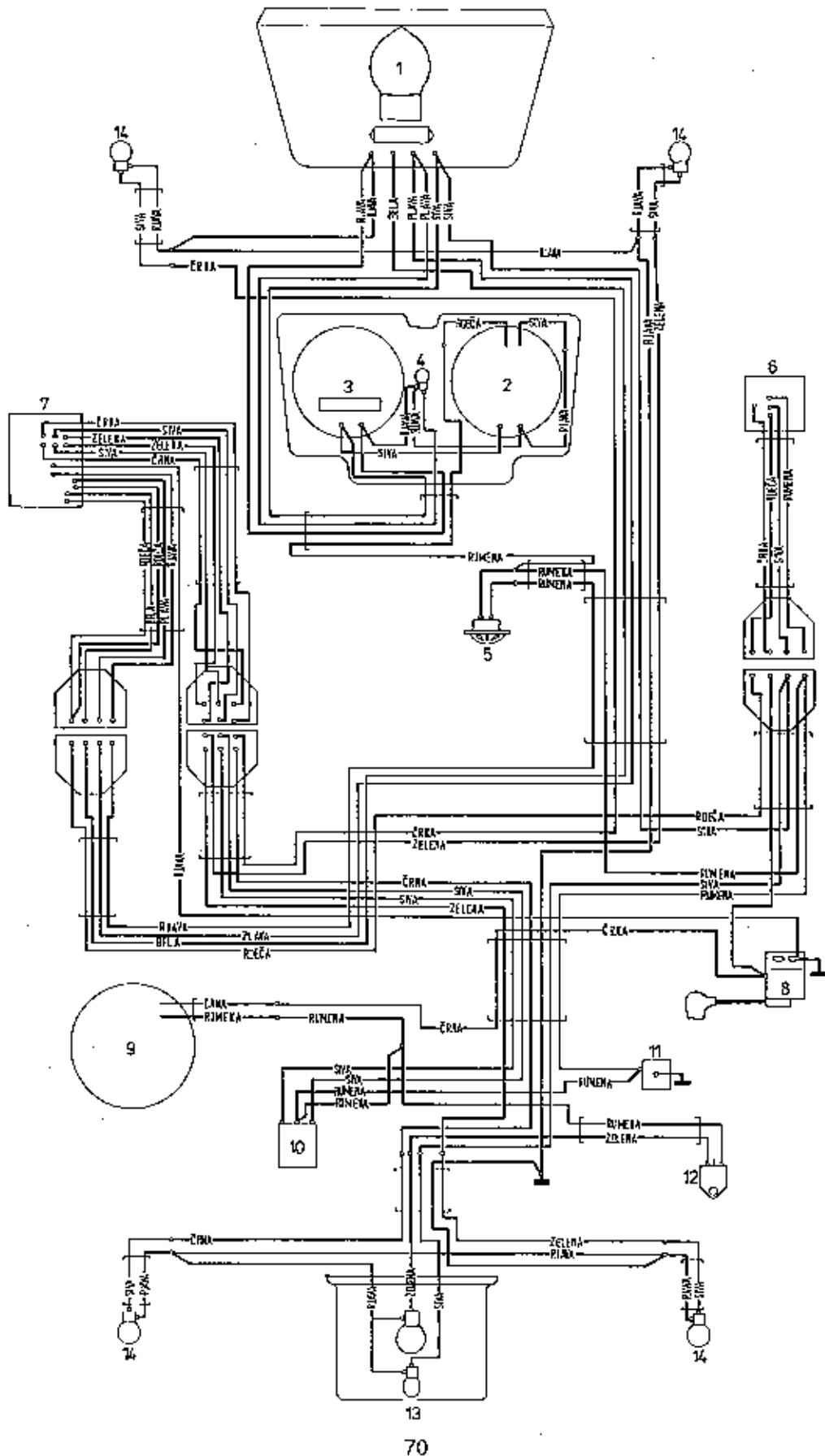

**Stop stikalo**

Elastično vezano na vzvod zadnje zavore

**Rele smerokaza in stabilizator napetosti**

Vezani direktno na rumeni žici magneta. Popravila ali kakršnekoli intervencije na elektroinstalaciji opravite na osnovi sheme (sl. 69 in 70) in na osnovi predhodne analize okvare.

Najprej ugotovite ali je mogoče napaka na sami žarnici in nato kontrolirajte električne vode, kontakte, stabilizator napetosti, rele smerokaza in svetilno tuljavo.

**Postopki kontrole**

**Svetilno tuljavo** kontrolirajte tako, da na rumeni žici iz magneta pri delujočem motorju ugotovimo napetost 12 V. Napetost ugotavljajte z instrumentom ali z žarnico.

Če toka ni, pomeni, da je tuljava pokvarjena in jo zamenjajte.

**Stabilizator napetosti** stabilizira napetost na 12 V. Kontrolirajte ga tako, da izklopite vse potrošnike in pri delujočem motorju kontrolirajte napetost na rumeni žici.

Napetost je višja, če je izklopljen stabilizator in znaša od 15 do 18 V, a v primeru, da jo merite preko stabilizatorja je napetost  $12 \pm 0,5$  V. Sistem lahko deluje tudi brez stabilizatorja, samo je nevarnost pregorevanja žamic večja.

**Rele smerokaza, stikala na krmilu in stop stikalo** kontrolirajte samo, če ne delujejo. Ugotoviti samo, če so priključki (kontakti) dobri in če je električni spoj zanesljiv. Če s ponovnim cinjenjem kontakta ali s podobnim posegom ne odklonite okvaro, zamenjajte celo stikalo.

**Vžigalnik dele vžigalnika** lahko kontrolirate v sklopu ali ločeno. Vezavo vžigalnika prikazuje slika 64 in 65.

**Vztrajnik** kontrolirate očno, da ni mehansko poškodovan in da konus dobro prilaga.

S pomočjo motorne gredi preverite opletanje. Maksimalno dovoljeno opletanje v aksialni smeri je 0,1 mm, a v radialni 0,3 mm.

**Stop switch**

Flexibly connected to the rear brake lever.

**Direction indicator relay and voltage stabilizing tube**

Connected directly to the two yellow magnet wires. Consult the wiring diagram (Figs. 69 and 70) and make a preliminary damage analysis before attempting any repair of the electrical system.

First establish if the bulb is faulty and then check the electrical leads, points, the voltage stabilizing tube, the direction indicator relay and the lighting coil.

**Checking procedures**

**The lighting coil** is checked by establishing 12 V voltage on the yellow wire from the magnet. The voltage is registered with an instrument or a bulb.

Absence of current indicates a damaged coil which should be replaced.

**Voltage stabilizing tube** stabilizes voltage at 12 V. Check it by switching off all consumers and inspect the yellow wire voltage with the engine in operation. The voltage is higher if the voltage stabilizing tube is turned off when it reads of from 15 to 18 V, but if it is measured via the stabilizing tube it reads  $12 \pm 0,5$  V. The system can operate also without the stabilizing tube, but the bulbs will blow more often.

**The direction indicator relay, the switches on the handlebar and the stop switch**

Should only be checked if they fail to operate. Establish if the points are in order and electric connection reliable. If by re-tinning the point or some similar procedure the damage can not be removed replace the switch.

**The magneto** components can be checked within the unit or separately. The method of connecting the magneto is shown in Figures 64 and 65.

**The flywheel** is checked visually for mechanical damage and for a good fit of the cone.

Check deflection by help of the crankshaft. The maximum permissible axial deflection is 0.1 mm and radial deflection 0.3 mm.

**Vžigalno tuljavo** notranjo ali zunanjo lahko kontrolirate samo če imate specialni mototester. Postopek kontrole v tem primeru predpisuje proizvajalec mototesterja.

Če testerja nimate na razpolago, napako lahko ugotovite, če obstoječo tuljavo zamenjate z vzorčno (zanesljivo dobro tuljavo).

**Prekinjevalne kontakte** kontrolirajte po vsaki servisni intervenciji. Kontrolirajte, če kontakti niso oksidirani ali ožgani in če odmični nos ni izrabljen.

Nastavite razdaljo na kontaktih prekinjevalca 0,35—0,45 mm in obvezno namažite klobučevinasti trak za mazanje odmičnega grebena rotorja.

#### ORODJE:

- izvijač
- križni izvijač
- kombinirane klešče

The **ignition coils**, both interior and exterior, can only be checked with a special mototester and the inspection procedure in that instance is prescribed by the mototester manufacturer.

If a mototester is not available, you can establish a possible fault by replacing the coil with a truly good sample coil.

The **contact breaker points** should be checked after every repair. Check the points for oxidization or burning and the cam nose for wear.

Set the contact breaker points gap to 0.35-0.45 mm and, without fail, grease the lubricating felt strip for the rotor cam ridge.

#### TOOLS:

- Screwdriver
- Crosshead screwdriver
- Combination pliers

### Dušilec (sl. 71)

Material — PVC

Oblika — prilagojena okviru

Pritrjen — na okvir z dvema vijakoma

### Filter

Tip — 221017 Donit

Material — papir

Filter demontirajte po potrebi zaradi čiščenja ali zamenjave. Predvidena kontrola filtra vsakih 500 km a zamenjava po potrebi (sl. 72)

Pri montaži zagotovite dobro prileganje in tesnost. Če je guma med dušilcem in uplinjačem razpokana ali trda zamenjajte jo z novo. Nepravilno zatesnjeni dušilec lahko povzroči nenormalno — neenakomerno delovanje motorja.

### Orodje

— izvijač

— ključ 8

### Uplinjač (sl. 73)

#### Za tipe AT, NTX, ATX 50

Tip — BING 18/12/110

Premer difuzorja — 12 mm

Glavna šoba — 58 standard

— 56, 60, 62, 64, 66, 68 dodatne

Opremljen — z ročico za hladni start

Za čiščenje ali zamenjavo izrabljenih in poškodovanih delov se uplinjač razstavi kot prikazuje sl. 74, 75 in 76.

#### Za tip BT 50

Tip — BING 1/19/23

Premer difuzorja — 18 mm

Glavna šoba — 75

Za čiščenje ali zamenjavo izrabljenih in poškodovanih delov se uplinjač razstavi kot prikazuje (sl. 77).

Razstavljene dele operite v bencinu in izpihajte z zrakom. Šob ne smete čistiti z žico, ker se lahko poškodujejo in se bi režim delovanja motorja spremenil.

#### Nastavitev:

Z regulirno matico na bovdenu doseči, da pri dodajanju plina nimamo praznega hoda.

Vijak za zrak pri prostem teku zatisniti in potem odviti za 1 ¼ do 1 ½ obrata

Startati motor in ko se segreje (3 do 5 min delovanja) opraviti z istim vijakom in vijakom za nastavitev minimalnih obratov fino nastavitev.

Pravilno nastavljen motor ima miren prosti tek in z dodajanjem plina obrati enakomerno naraščajo.

### Intake silencer (Fig. 71)

Material: PVC

Shape: Adapted to the frame.

Fitting: Fixed to the frame with two screws.

### Filter

Type: 221017 Donit

Material: Paper

If necessary, remove the filter for cleaning or replacing. The filter should be checked every 500 kilometers and replaced as required. (Fig. 72)

When installing the filter, make sure it is a tight fit. If the rubber between the silencer and the carburettor is cracked or hard, replace it with a new one. An improperly tightened silencer may cause abnormal/jerky engine operation.

### Tools:

Screwdriver

Spanner 8

### Carburettor (Fig. 73)

#### For AT, NTX, ATX 50 models

Type: BING 18/12/10

Intake dia: 12 mm

Main jet: 58, standard

56, 60, 62, 64, 66, 68, optional

Equipped with choke lever. To clean or replace worn or damaged parts, dismantle the carburettor as shown in Figures 74, 75, and 76.

#### For BT 50 model

Type: BING 1/19/23

Intake dia: 18 mm

Main jet: 75

To clean or replace worn or damaged parts, dismantle the carburettor as shown in Figure 77.

Wash the dismantled parts in petrol and blow them out with air. The jets should never be cleaned with wire or else, they may be damaged thus affecting engine operation.

#### Setting:

Use the control cable adjusting nut to ensure there is no idle run at throttling up.

Tighten the idle air control screw and unscrew it by 1-1/4 to 1-1/2 turn.

Start the engine and when it warms after 3 or 5 minutes make fine adjustment with the same screw and the minimum revs setting screw.

A properly adjusted engine has a quiet run and the number of revolutions increases evenly when throttling up.



71



74



72



75



73



76

## Orodje

- izvijač
- križni izvijač
- ključ 10

## Izpušni glušnik

- Tip — »A« za modele AT, BT 50 (sl. 78)  
Tip — »B« za modele ATX, NTX 50 (sl. 79)

## Opozorilo

Pri naročanju rezervnega dela obvezno označite za kateri model je naročeni del, ker so ene vrste izpuhov bolj, druge manj zadušene in se s tem v zvezi spremeni tudi maksimalna hitrost vozila.

Demontirajte ga, po potrebi največkrat zaradi čiščenja. Izpuh, ki ima na steni usedline in ogorke od olja zmanjšuje moč motorja.

Vzrok prekomernega nabiranja usedlin je lahko:

- nekvalitetno olje v mešanici
- prevelika količina olja v mešanici
- slabo izgorevanje zaradi svečke ali nepravilnega vžiga

Postopek čiščenja izpuha je lahko mehanski ali s posebnim kemijskim sredstvom

## Orodje:

- izvijač
- križni izvijač
- kombinirane klešče
- ključ 10
- ključ 11

## Tools

- Screwdriver
- Crosshead screwdriver
- Spanner 10

## Exhaust silencer

- »A« type for AT, BT 50 models (Fig. 78)  
»B« type for ATX and NTX 50 models (Fig. 79)

## Warning

When ordering spare parts, you should, without fail, quote the model the ordered parts refer to since the exhaust damping degrees vary thus altering also the top speed of the machine.

Remove the exhaust silencer, if necessary, for cleaning purposes. Exhausts with carbon build up and burnt oil on their walls cause a drop in engine output.

Possible reasons for excessive build up:

- Inferior quality of oil in the mixture
  - Excessive oil in the mixture
  - Poor combustion due to spark plug or misfire
- The exhaust can be cleaned either mechanically or with a special chemical agent.

## Tools

- Screwdriver
- Crosshead screwdriver
- Combination pliers
- Spanner 10
- Spanner 11



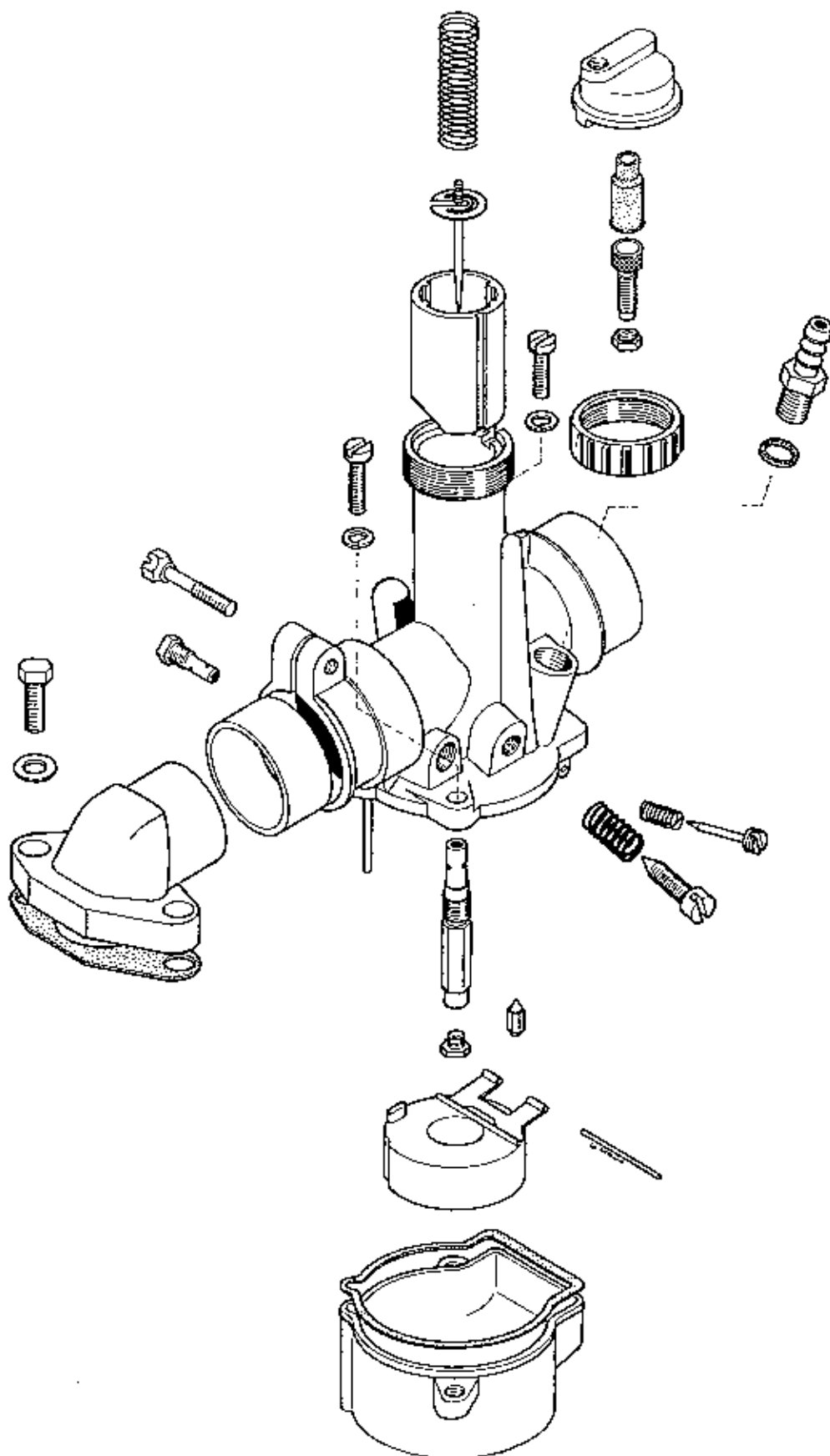

**Okvir in nihajni krak**

Varjena konstrukcija iz kvadratnih cevi.

**Krmilo**

Okrogla cev  $\varnothing 22$

Nosilnost — 150 kg

Potrebno redno mazanje (z mastjo) ležajnih puš, nihajnih vilic.

V primeru obrabe ležajnih puš nihajnega kraka in ležajne skodelice vilic zamenjati z novimi. Moment zatiskanja matic nihajnega kraka 50 Nm.

**Orodje:**

- ključ 13
- ključ 17
- ključ 19
- izvijač
- kladivo
- $\varnothing 12 \times 200$

**Frame and swinging arm**

Welded construction of square tubing.

**Handlebar**

Round tube:  $\varnothing 22$

Carrying capacity: 150 kg

The bearing bushes and the swinging arm should be regularly greased.

In case of wear of the swinging arm bearing bushes and fork bearing cups, these should be replaced with new ones. The swinging arm nuts are torqued to 5.0 kgf m.

**Tools:**

- Spanner 13
- Spanner 17
- Spanner 19
- Screwdriver
- Hammer
- Rod  $\varnothing 12 \times 200$

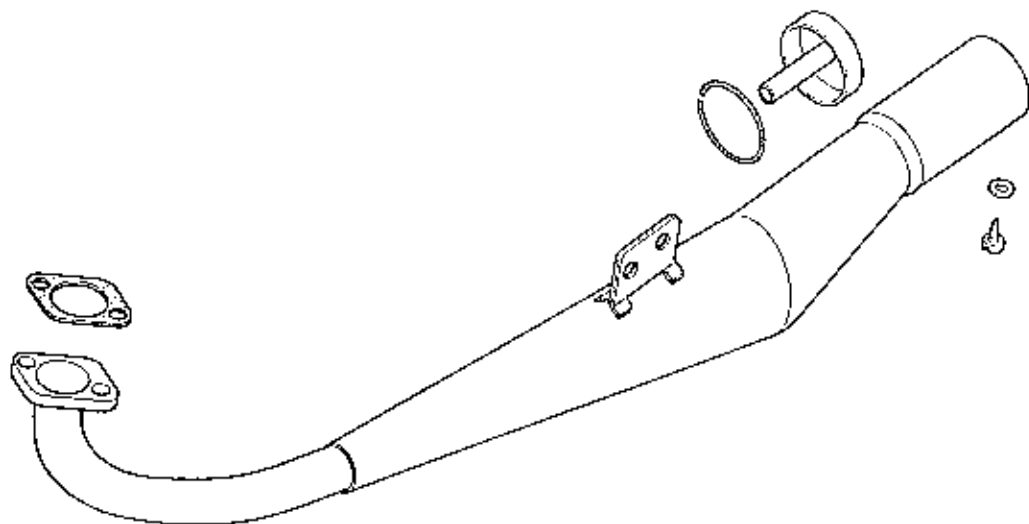

78

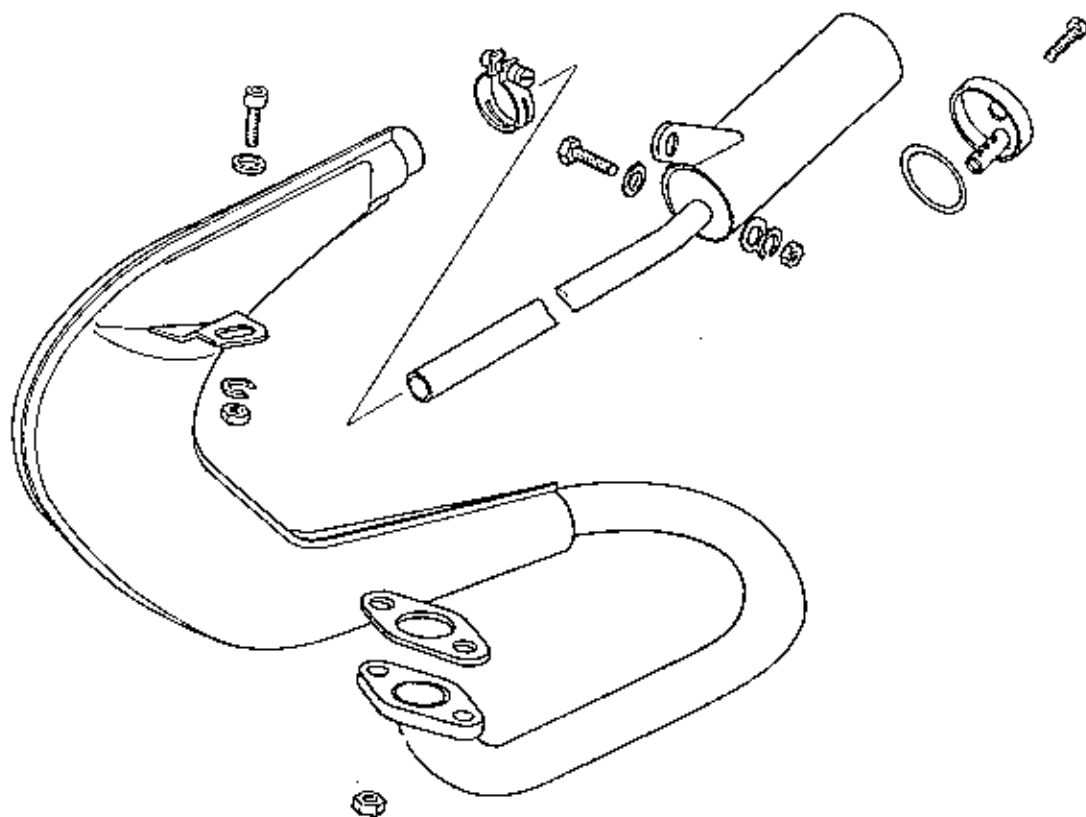

79

**Vilice**

Tip — Marzocchi, oljno vzmetne  
Hod vilic — 100 mm za AT in ATX 50  
— 90 mm za BT 50  
— 160 mm za NTX 50  
Olje — 2 × 130 cm<sup>3</sup> SAE 30

Demontažo kompletnih vilic opraviti le pri zamenjavi spodnje vilične vezi, ali vilic komplet. Demontažo opraviti po zaporedju kot prikazujejo slike (80, 81, 82 in 83).

Olje izpustiti z odvijanjem vijaka (sl. 84).

Levo in desno nogo razstaviti kot je prikazano na slikah (85, 86, 87 in 88).

Sestavljanje opraviti po obratnem zaporedju od razstavljanja.

Odviti vijadni čep (sl. 89).

Naliti v vsaki krak 130 cm<sup>3</sup> olja SAE 30 (sl. 90).

**Front fork**

Type: Marzocchi, oil spring  
Fork travel: 100 mm with AT and ATX 50  
90 mm with BT 50  
160 mm with NTX 50  
Oil: 2 × 130 cc SAE 30

The front fork is removed only when replacing the bottom fork yoke or the unit assy. Remove in the sequence as shown in Figures 80, 81, 82, and 83. Drain oil by unscrewing the oil drain plug. (Fig. 84) Dismantle the left-hand and right-hand legs as shown in Figures 85, 86, 87, and 88.

Re-assemble in the reverse of the removal sequence.

Unscrew the thread plug. (Fig. 89)

Pour 130 cc of SAE 30 oil into either leg. (Fig. 90)

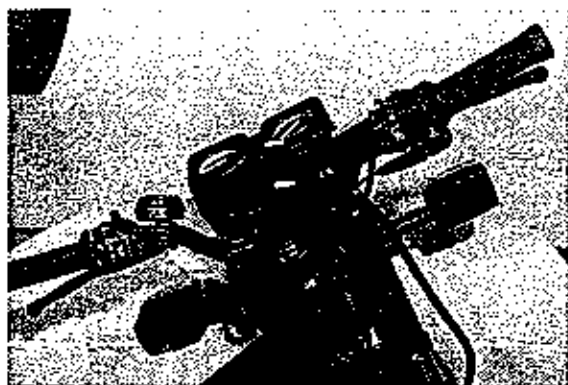

80

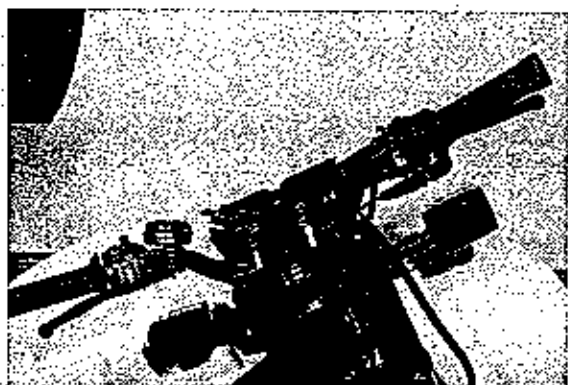

81

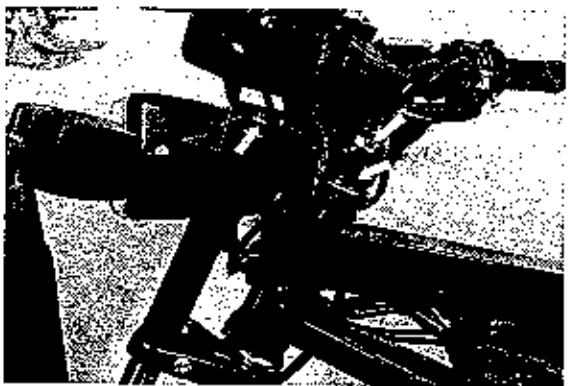

82

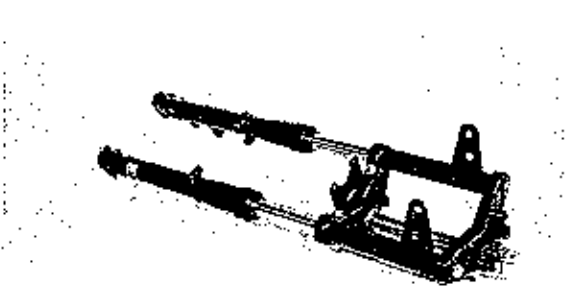

83

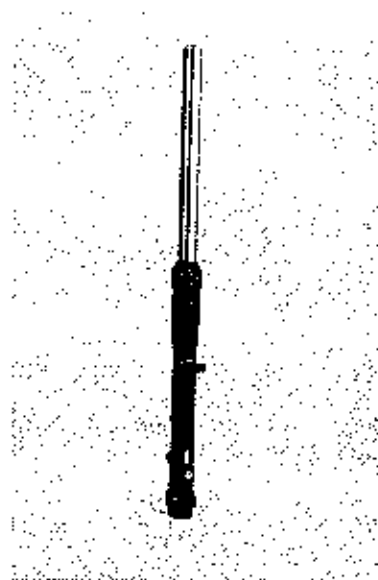

84

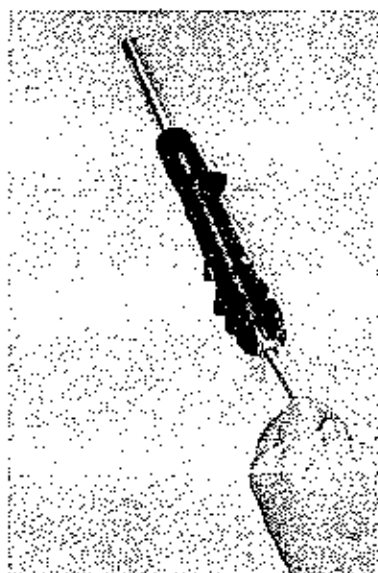

85

**Blažilci**

Tip — Marzocchi

Hod blažilca — 60 mm za AT, BT in ATX 50  
— 35 mm za NTX 50Modeli — AT, ATX in BT 50 imajo par  
blažilcev (sl. 91)Model — NTX 50 ima 1 komad  
centralni blažilec (sl. 92)Moment pritegovanja vijakov zadnjih blažilcev  
— 35 NmPopravilo blažilcev ni predvideno in v primeru okvare  
zamenjati komplet

Orodje:

**Shock absorbers**

Type: Marzocchi

Shock travel: 60 mm with AT, BT, and ATX 50  
35 mm with NTX 50Models: AT, ATX, and BT 50 have a pair of  
shocks. (Fig. 91)

Model: NTX 50 has one central shock. (Fig. 92)

The rear shock screws are torqued to 3.5 kgf m.

Repair of shocks should be avoided and in case of  
damage the unit should be replaced.

Tools:

**Vilice:**

- izvijač
- križni izvijač
- imbus ključ 4
- imbus ključ 7
- ključ 10
- ključ 11
- ključ 13
- ključ 17
- ključ 19
- ključ 30
- kleščice za segerjeve varovalke — notranje
- kladivo

**Front fork**

- Screwdriver
- Crosshead screwdriver
- Allen key 4
- Allen key 7
- Spanner 10
- Spanner 11
- Spanner 13
- Spanner 17
- Spanner 19
- Spanner 30
- Internal Sg-circlip pliers
- Hammer

**Blažilci:**

- ključ 17

**Shock absorbers**

- Spanner 17

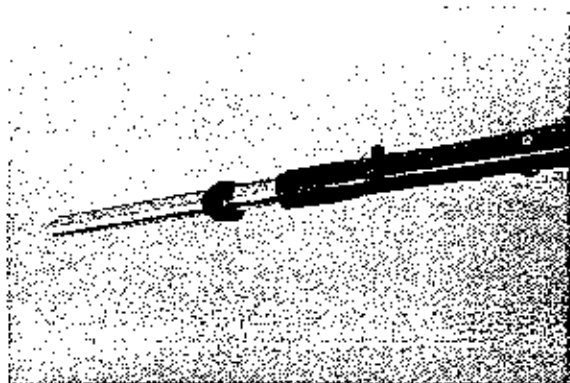

86

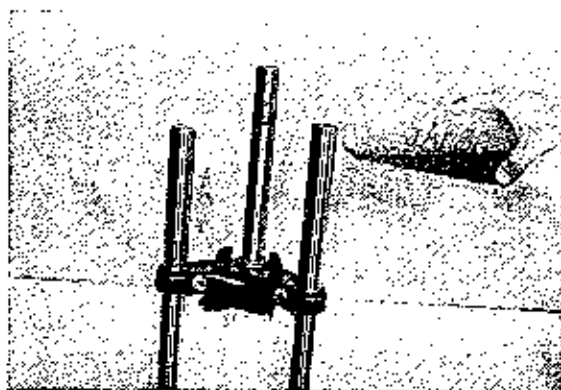

90

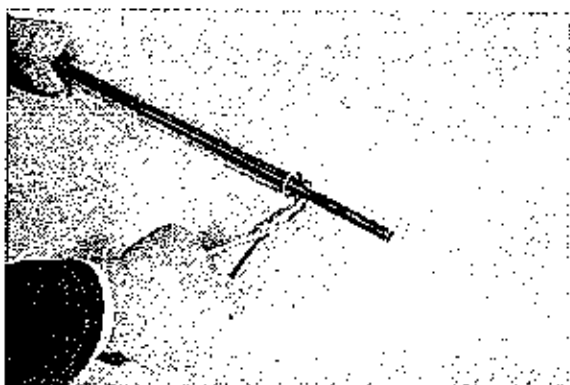

87

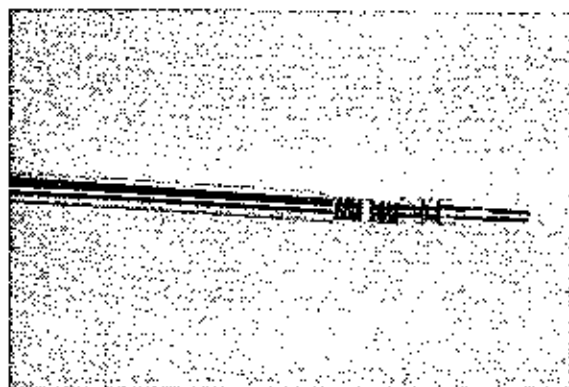

88

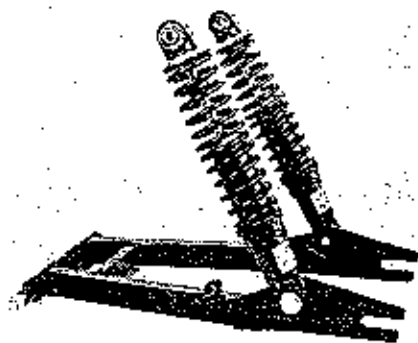

91

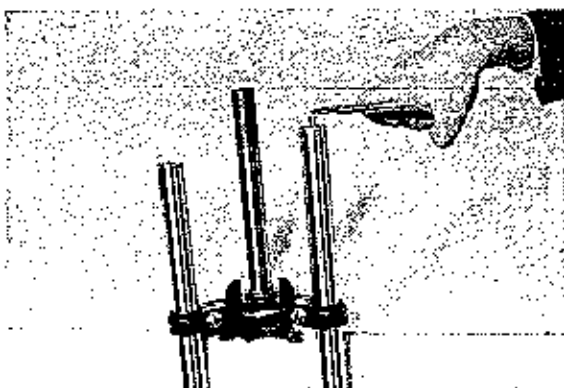

89

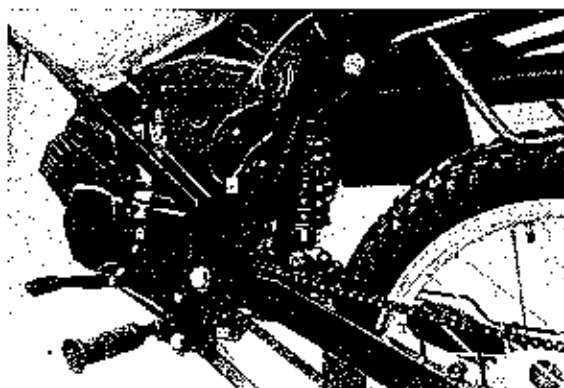

92

**PREDNJE KOLO****Material:**

- al. zlitina za tip AT in BT 50
- žbičeno z valjanim platiščem za tip ATX in NTX 50

**Dimenzija platišča:**

- lito platišče 1/1,35 × 17" za tip ATX in BT 50
- valjano platišče 2,5 × 17" za tip ATX 50
- valjano platišče 1,6 × 18" za tip NTX 50

**Dimenzije gum:**

- 2,5 × 17" za tip AT 50, BT 50 in ATX 50
- 2,75 × 18" za tip NTX 50

**FRONT WHEEL****Material:**

- Al-alloy with AT and BT 50 models
- Spoked with rolled rim with ATX and NTX 50 models

**Rim sizes:**

- Cast rim 1/1.35 × 17" with ATX and BT 50 models
- Rolled rim 2.5 × 17" with ATX 50 model
- Rolled rim 1.6 × 18" with NTX 50 model

**Tyre sizes:**

- 2.5 × 17" with AT 50, BT 50, and ATX 50 models
- 2.75 × 18" with NTX 50 model

**ZADNJE KOLO****Material:**

- al. zlitina za tip AT 50 in BT 50
- žbičeno z valjanim platiščem za tip ATX 50 in NTX 50

**Dimenzija platišča:**

- lito platišče 1/1,6 × 17" za tip AT 50 in BT 50
- valjano platišče 2,75 × 17" za tip ATX 50
- valjano platišče 2,75 × 18" za tip NTX 50

**Dimenzije gum:**

- 2,75 × 17" za tip AT, ATX in BT 50
- 3,00 × 18" za tip NTX 50

**Pritisk zraka v:**

- prednji zračnici 1,7 bar
- zadnji zračnici 1,9 bar (2,1 bar za dve osebi)

**REAR WHEEL****Material:**

- Al-alloy with AT 50 and BT 50 models
- Spoked with rolled rim with ATX 50 and NTX 50 models

**Rim sizes:**

- Cast rim: 1/1.6 × 17" with AT 50 and BT 50 models
- Rolled rim: 2.75 × 17" with ATX 50 model
- Rolled rim: 2.75 × 18" with NTX 50 model

**Tyre sizes:**

- 2.75 × 17" with AT, ATX and BT 50 models
- 3.00 × 18" with NTX 50 model

**Tyre pressure:**

- Front: 1.7 bar
- Rear: 1.9 bar (2.1 bar for two persons)



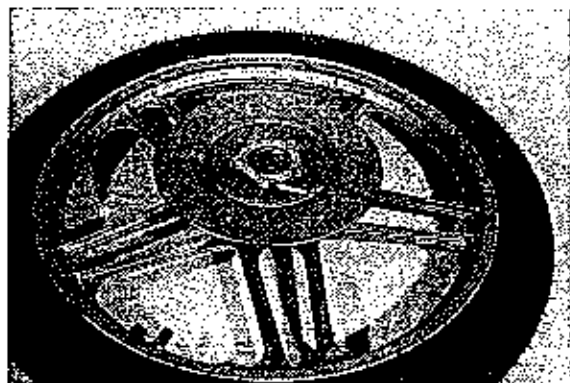

93

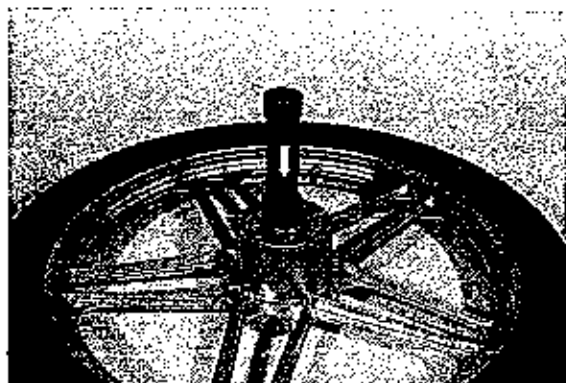

96

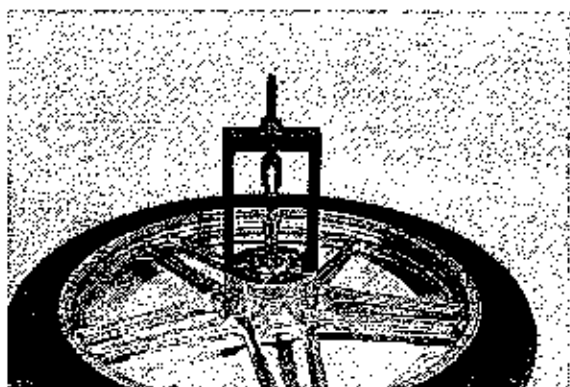

94

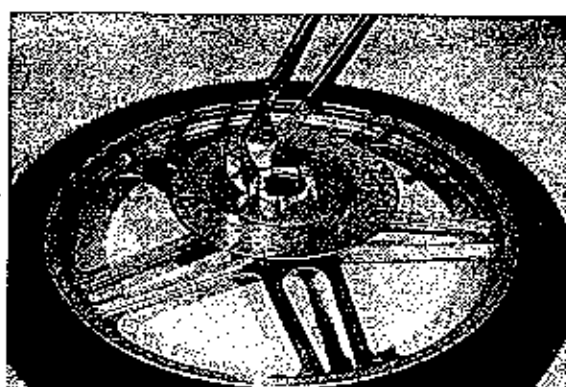

97

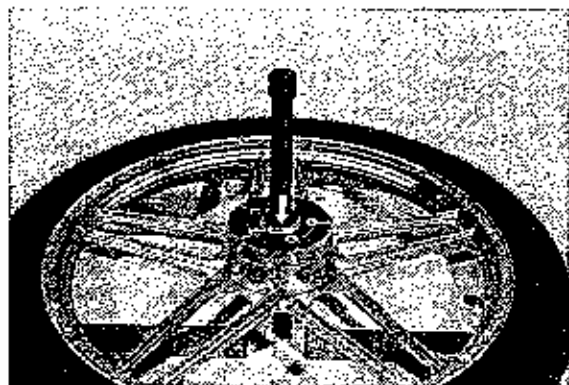

95

Kolesa demontirati zaradi mazanja ali zamenjave posameznih sestavnih delov.

Ležaje kolesa redno mazati z mastjo. Za mazanje po možnosti uporabljati vodoodporne masti.

Prednje kolo demontirajte z vilic. Pri demontaži predhodno popustite vijak na levi nogi prednjih vilic in ločite bovden od pogona merilnika hitrosti.

Postopek razstavljanja, sestavljanja kolesa (za tip AT 50 in BT 50) je prikazan na fotografijah (sl. 93, 94, 95, 96 in 97).

Zadnje kolo demontirajte iz nihajnega kraka.

Postopek razstavljanja zadnjega kolesa je prikazan na fotografijah (sl. 98, 99, 100, 101 in 102). Pri razstavljanju ležaja se notranja skodelica poškoduje in jo obvezno zamenjati.

Pri montaži verižnika pazite na položaj matice — odliči naslon v pestu onemogoča vrtenje matice.

### Momenti zategovanja:

- Glavne matice kolesa - 50—55 Nm
- Vijaki za pritrditev koluta prednje zavore — 12 Nm
- Vijaki za pritrditev verižnika zadnjega kolesa — 15 do 18 Nm

### Orodje:

- ključi 10, 11, 17, 19, 24
- kladivo
- palica  $\varnothing 12 \times 200$
- vtisni trn 702.856
- spec. orodje 706.485, 706.427

Remove the wheels to lubricate or replace individual components.

Regularly grease the wheel bearings, using, if possible, water-resistant grease brands.

Remove the front wheel from the fork. First slacken the screw on the front fork left-hand leg and detach the control cable from the speedometer drive gear-box.

The procedures of dismantling and assembling with AT 50 and BT 50 models are shown in Figures 93, 94, 95, 96, and 97.

Remove the rear wheel from the swinging arm.

The rear wheel dismantling procedure is shown in Figures 98, 99, 100, 101, and 102. The inner cup gets damaged during dismantling and it should, therefore, be replaced without fail.

When installing the chain sprocket, note carefully the nut location — the cast hub shoulder prevents the nut from turning round.

### TORQUES

Main wheel nuts	5.0-5.5 kgf m
Front brake disc fixing screws	1.2 kgf m
Rear wheel chain sprocket fixing screw	1.5-1.8 kgf m

### Tools:

- Spanners 10, 11, 17, 19, 24
- Hammer
- Rod  $\varnothing 12 \times 200$
- Impressing pin 702.856
- Special tools 706.485, 706.427

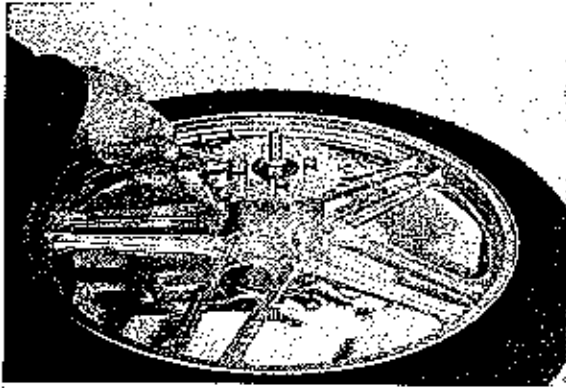

98

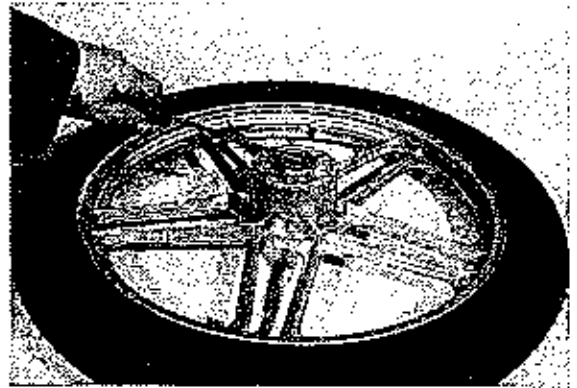

101

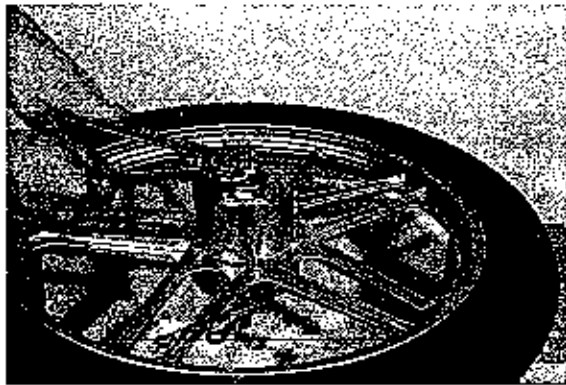

99

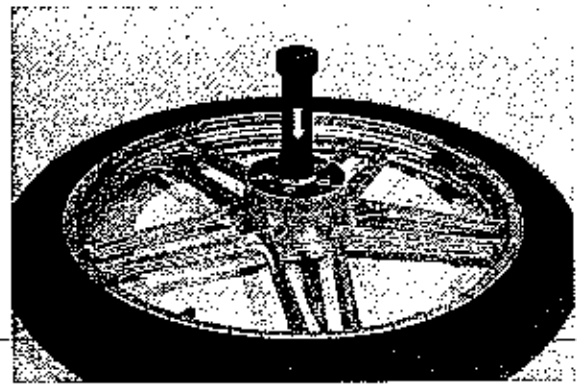

102

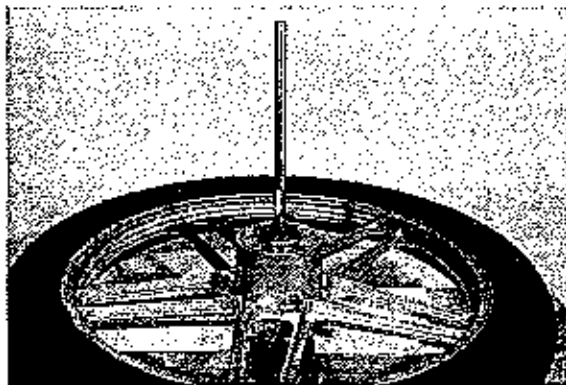

100

### Prednja zavora:

#### Tip

- kolutna hidravlična Ø 220 za tip AT, BT in NTX 50
- bobnasta Ø 105 za tip ATX 50
- površina zavornih oblog — 21 cm<sup>2</sup>
- debelina novih zavornih oblog — 4 mm
- maksimalna obraba zavornih oblog do debeline — 2 mm

### Zadnja zavora

- bobnasta — Ø 90 za AT, Ø 125 za BT in ATX 50  
— Ø 110 za NTX 50
- površina zavornih oblog — 24 cm<sup>2</sup>
- debelina novih zavornih oblog — 4 mm
- maksimalna obraba zavornih oblog do debeline — 2 mm

### Prednja kolutna hidravlična zavora

Tlačni del zavornega sistema je montiran na desni strani krmila in se v njem ustvarja tlak s pritiskom na ročico. Tlak zavorne tekočine v zavornih cilindrih deluje na bate, kateri pritiskajo na zavorne ploščice. Zavorni učinek je odvisen od tlaka v sistemu in stanja zavornih oblog. Pri popravilu zagotovite tesnost ter po potrebi zamenjajte tesnilne gumice. V sistem nalivajte zavorno tekočino za hidravlične zavora (U 2).

Po vsakem popravilu ali zamenjavi zavorne tekočine obvezno odzračite zavorni sistem. Zavorne ploščice redno kontrolirajte in v primeru velike obrabe oblog (min. debelina 2 mm) zamenjajte ploščice z novimi. (sl. 102, 103, 104, 105, 106, 107 in 108).

Prekomerno obrabljene zavorne ploščice lahko poškodujejo zavorni kolut. Poškodovani zavorni kolut prebrusite, če so zareze - poškodbe koluta večje od približno 0,3 mm zamenjajte kolut z novim.

### Zadnja zavora

Zavora deluje s pritiskom desne noge na pedal zavora. Zavorni učinek je odvisen od pritiskne sile na pedal, prileganja zavornih čeljusti na boben in stanja zavornih oblog. V primeru, da so zavorne obloge zavornih čeljusti obrabljene (min. debelina oblog 2 mm) zamenjajte zavorne čeljusti z novimi.

Nastavitev zavora opravite z nastavno matico zavornega droga.

### Front brake

#### Type:

- Disc hydraulic Ø 220 with AT, BT, and NTX 50 models
- Drum brake Ø 105 with ATX 50
- Brake lining area 21 sq. cm
- New brake lining thickness 4 mm
- Maximum brake lining wear upto 2 mm in thickness

### Rear brake

- Drum Ø 90 with AT model, Ø 125 with BT and ATX 50  
Ø 110 with NTX 50
- Brake lining area 24 sq. cm
- New brake lining thickness 4 mm
- Maximum brake lining wear upto 2 mm in thickness

### Hydraulic disc front brake

The pressure section of the brake system is fitted on the right-hand handlebar and pressure is created in it by pressing down the lever. The brake fluid pressure in the brake claws acts on pistons which, in turn, press down the brake pads.

The braking effect depends on the system pressure and the condition of brake linings. When repairing the system, make sure it tightens properly and, if necessary, replace the sealing rubbers. Fill the system with hydraulic brake fluid U2.

After every repair or change of the brake fluid you should, without fail, air the brake system. Regularly check the brake pads and in case of heavy wear of linings (whose thickness should be not less than 2 mm), replace the pads with new ones. (Figs. 102, 103, 104, 105, 106, 107, and 108)

Badly worn brake pads may damage the brake disc. Regrind the damaged brake disc, but if the scratches on the disc exceed about 0.3 mm, replace the disc with a new one.

### Rear brake

The rear brake is activated by depressing the pedal with the right-hand foot. The braking effect depends on the force applied to the pedal, the brake shoe and drum fit, and on the brake lining condition.

When the brake shoe linings are worn (their thickness should be not less than 2 mm), replace the brake shoes with new ones.

The brake is set by help of the brake rod adjusting nut.



103

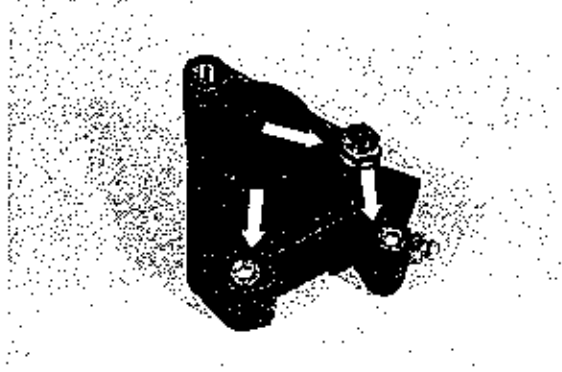

106

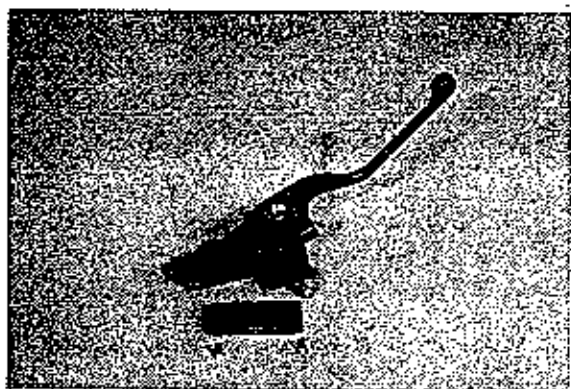

104

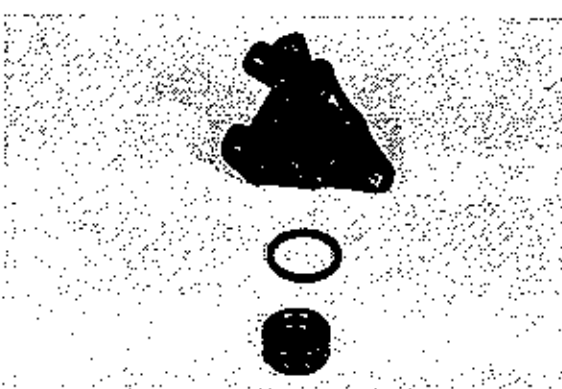

107

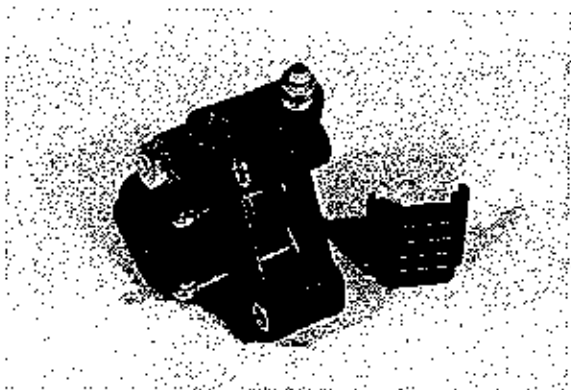

105

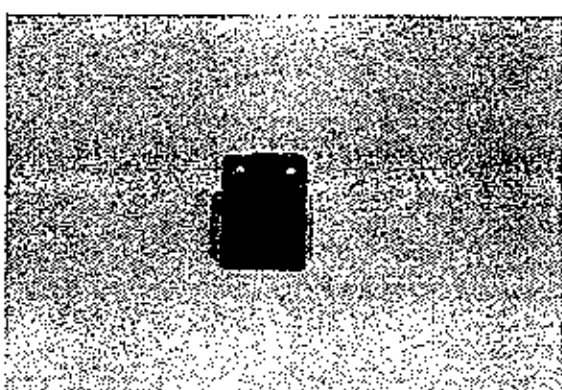

108

### Momenti zategovanja vijakov:

— cevni priključki prednje zavore	25 Nm
— vijaki za pritrditev ročice na krmilo	10 Nm
— vijaki na ohišju zavornih cilindrov M6	10 Nm
— vijaki na ohišju zavornih cilindrov M8	20 Nm

### Orodje:

- imbus ključ 5
- imbus ključ 6
- kleščice
- izvijač
- ključi 10, 11, 13, 17, 19 in 24

### Screw torques:

Front brake pipe couplings	2.5 kgf m
Screws for fixing the lever on the handlebar	1.0 kgf m
Brake claw housing screws M6	1.0 kgf m
Brake claw housing screws M8	2.0 kgf m

### Tools

- Allen key 5
- Allen key 6
- Pliers
- Screwdriver
- Spanners 10, 11, 13, 17, 19, and 24

## REZERVOAR

Material — vlečena pločevina

Zaščita — lakiran

— barve: srebrna, črna, bela, AT, BT 50

— barve: rdeča, črna, bela, ATX 50

— barve: bela, zelena, rdeča, NTX 50

Volumen — 9,5 l za model AT, BT, ATX 50

— 16 l za model NTX 50

Oddušek rezervoarja — na pokrovu

Pipica za gorivo:

Položaji:

odprto, zaprto, rezerva

## MASKE

Material — PVC lakiran

Konstrukcija — estetsko in funkcionalno oblikovane, pokrivajo sestavne dele motorja in tako zmanjšujejo zračni upor.

## BLATNIKI

Material — PVC lakiran

Konstrukcija — ščiti dele motorja in voznika pred vodo in blatom.

## SEDEŽ

Material — šivani skaj

Pritrditev — na okvir s posebnim zapenjalom (ročica na desni strani)

Konstrukcija — istočasno služi kot pokrov orodne škatle

### Orodje:

- izvijač
- križni izvijač
- ključ 10
- ključ 13
- ključ 17

## FUEL TANK

Material: Drawn sheet metal

Protection: Enamelled; colours:

black, white, silver AT, BT 50

black, white, red ATX 50

green, red, white NTX 50

Capacity: 9.5 litres with AT, BT, ATX 50 models  
16 litres with NTX 50

Fuel tank vent: On the cover

Fuel feed tap positions:

Open, Closed, Reserve

## SIDE COVERS

Material: PVC enamelled

Construction: Aesthetically and functionally shaped, enclosing engine components thus reducing air resistance.

## MUDGUARDS

Material: PVC enamelled

Construction: Protect engine parts and driver against water and mud.

## SEAT

Material: Sewn leather imitation

Fitting: On the frame with a special seat snap (lever on the right-hand side)

Construction: Serves also as tool box cover.

### Tools

- Screwdriver
- Crosshead screw
- Spanner 10
- Spanner 13
- Spanner 17

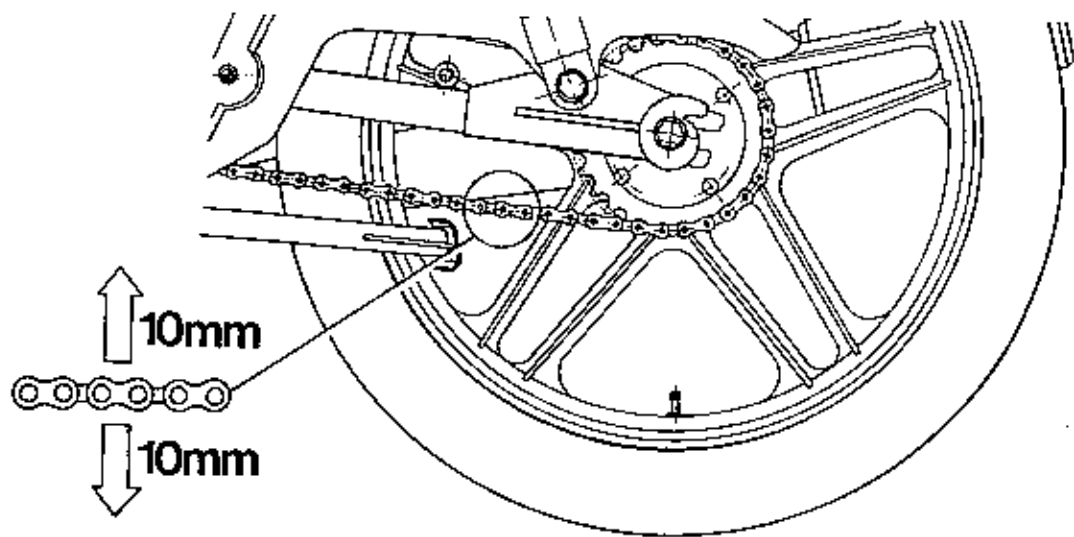

109

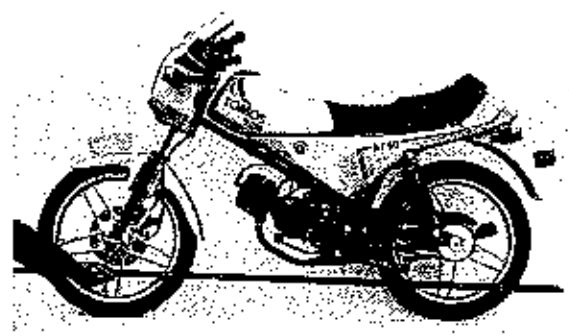

110

Po vsaki servisni intervenciji obvezno preizkusiti vozilo.

Predhodno opravite še določene kontrole in nastavitve.

### Kontrola

Vizuelno kontrolirati:

- zategnjenost vijakov
- nivo olja v menjalniku
- gorivo v rezervoarju
- tlak v zračnici
- olje v rezervoarčku hidravlične zavore
- kompletnost vozila
- vzmetenje prednjih in zadnjih blažilcev

### Nastavitve

- sled koles in zategnjenost verige — regulirati z natezalcem verige. Zagotoviti morate, da zadnje kolo sledi prvemu in da je upogib verige od nevtralnega položaja  $\pm 10$  mm (sl. 109 in 110)

Orodje:

- ključ 19
- ravna letev 2,5 m

### Zavore

Prednjo zavoro nastavite tako, da zavorna ročica ima približno 10—15 mm prostega hoda.

Drog zadnje zavore nastavite z nastavno matico droga.

Orodje:

- imbus ključ 3
- ključ 10
- ključ 11

### Sklopka

Nastavitev sklopke opravite z nastavno matico na bovdeni pri menjalniku.

Sklopka je pravilno nastavljena ko ročica sklopke na krmilu ima 10—15 mm praznega hoda.

V primeru, da je sklopko nemogoče nastaviti z nastavnim vijakom na bovdeni, regulacijo opravite z nastavno matico ima sklopke (obvezno jo zavarujte z razcepko).

Orodje:

- ključ 10
- ključ 11
- pl. klešče
- ključ 30

Each time the machine is repaired, test it without fail.

Make preliminary checkings and settings.

### Inspection

Inspect visually:

- Screws for tightness
- Oil level in the gearbox
- Fuel in the tank
- Inner tube pressure
- Oil in the hydraulic brake small tank
- If the machine is complete
- Front and rear suspension

### Settings

Wheel track and chain tension:

Adjust with the chain tension adjuster. Make sure the rear wheel follows the track of the front wheel and the chain sag from neutral position amounts to  $\pm 10$  mm. (Figs. 109 and 110)

Tools

- Spanner 19
- Straight lath 2.5

### Brakes

Set the front brake so as to allow a 10-15 mm free play of the brake lever.

Set the rear brake rod with the rod adjusting nut.

Tools

- Allen key 3
- Spanner 10
- Spanner 11

### Clutch

Set the clutch with the adjusting nut on the control cable by the gearbox. The clutch has been properly set when the clutch lever on the handlebar has a 10 to 15 mm free play. If the clutch cannot be set with the control cable adjusting screw, set it with the adjusting nut on the clutch axle, securing it, without fail, with a split pin.

Tools

- Spanner 10
- Spanner 11
- Flat nose pliers
- Spanner 30



Delo Work	na km 500 every	1500	3000	6000	9000
<b>MAZANJE Z OLJEM LUBRICATING WITH OIL</b>					
1. Menjava olja v menjalniku (400 cm <sup>3</sup> ) Changing the gearbox oil (400 cc)	x			x	
2. Zglobi komandnih ročic, bovdeni, ležišče stojala Lubricating the control lever joints, control cables, stand pivots	x	x	x	x	x
3. Veriga Lubricating the chain	x	x	x	x	x
4. Klobočevinasti trak prekinjevalnika Lubricating the contact breaker felt strip				x	
5. Menjava olja v prednjih vilicah Changing oil in the front fork	x			x	
<b>MAZANJE Z MASTJO LUBRICATING WITH GREASE</b>					
7. Ležaji koles Wheel bearings				x	
8. Ležaj sklopke Clutch bearing	x	x	x	x	x
9. Ležaj krmila Handlebar bearing				x	
10. Ležajne puše zadnjih vilic Swinging arm bearing bushes				x	
<b>ČIŠČENJE CLEANING</b>					
11. Svečka Spark plug	x	x	x	x	x
12. Uplinjač, filter za zrak Carburettor, air filter	x	x	x	x	x
13. Glava valja, teme bata in izpušni kanal Cylinder head, piston crown and exhaust channel					x
14. Izpušna cev Exhaust pipe	x	x	x	x	x
15. Zunanje površine Exterior surfaces	x	x	x	x	x
<b>KONTROLE IN NASTAVITVE CHECKINGS AND SETTINGS</b>					
16. Nivo olja v menjalniku Gearbox oil level			x	x	x
17. Prednje vilice — olje Front fork oil level			x	x	x
18. Zadnji blažilec Rear shock absorber				x	
19. Luči Lights	x	x	x	x	x
20. Kontakti prekinjevalnika Contact breaker points	x			x	
21. Predvžig Ignition advance				x	

22. Nastavitev sklopke in zavor Clutch and brake settings	×	×	×	×	×
23. Razdalja med elektrodama svečke Spark plug electrodes gap	×	×	×	×	×
24. Zračnost ležajev krmila Handlebar bearing clearances	×	×	×	×	×
25. Zračnost ležajev koles Wheel bearing clearances	×	×	×	×	×
26. Sled koles in centriranje Wheel tracks and alignment	×	×	×	×	×
27. Napetost verige (10 mm gor-dol) Chain tension (10 mm up and down movement)	×	×	×	×	×
28. Tlak v zračnicah Inner tube pressure	×	×	×	×	×
29. Prosti tek in plin Neutral run and throttle	×	×	×	×	×
30. Zategniti magnetni vztrajnik (28-30 Nm) Torquing the flywheel to 2.8 to 3.0 kgf m	×	×	×	×	×
31. Zategniti vse vijake Tightening all the screws	×	×	×	×	×
32. Preizkušnja vozila Testing the machine	×	×	×	×	×

**SPECIALNO ORODJE** sl. 111

**SPECIAL TOOLS** Fig. 111

Kat. št.	Naziv	Code No.	Description
736.533	Snemalec vztrajnika CEV	736.533	CEV flywheel puller
732.746	Snemalec vztrajnika ISKRA	732.746	ISKRA flywheel puller
702.856	Puša za vtiskavanje ležajev motorne gredi	702.856	Bush for impressing crankshaft bearings
706.485	Snemalec ležaja	706.485	Bearing puller
708.253	Ključ za montažo in demontažo ojnične puše Ø 10	708.253	Spanner for fitting and removing the conrod bush Ø 10
716.714	Ključ za montažo in demontažo ojnične puše Ø 12	716.714	Spanner for fitting and removing the conrod bush Ø 12
714.011	Priprava za popravilo motorja	714.011	Engine repair device
730.159	Ključ za blokiranje sklopke	730.159	Clutch locking spanner
735.753	Vilice	735.753	Fork
731.183	Ključ za blokiranje verižnika	731.183	Chain sprocket locking spanner
732.202	Ključ za blokiranje vztrajnika	732.202	Flywheel locking spanner
732.193	Nastavek merilne ure	732.193	Dial gauge holder
011.008	Podaljšek merilne ure	011.008	Dial gauge extension
975.709	Merilna ura	975.709	Dial gauge
706.472	Priprava (spada k delu 706.485)	706.472	Device (for tool 706.485)
735.888	Priprava za razstavljanje ohišja	735.888	Crankcase dismantling tool
736.262	Vijak (spada k 735.888)	736.262	Screw (for part 735.888)
731.155	Snemalec ležajev	731.155	Bearing puller

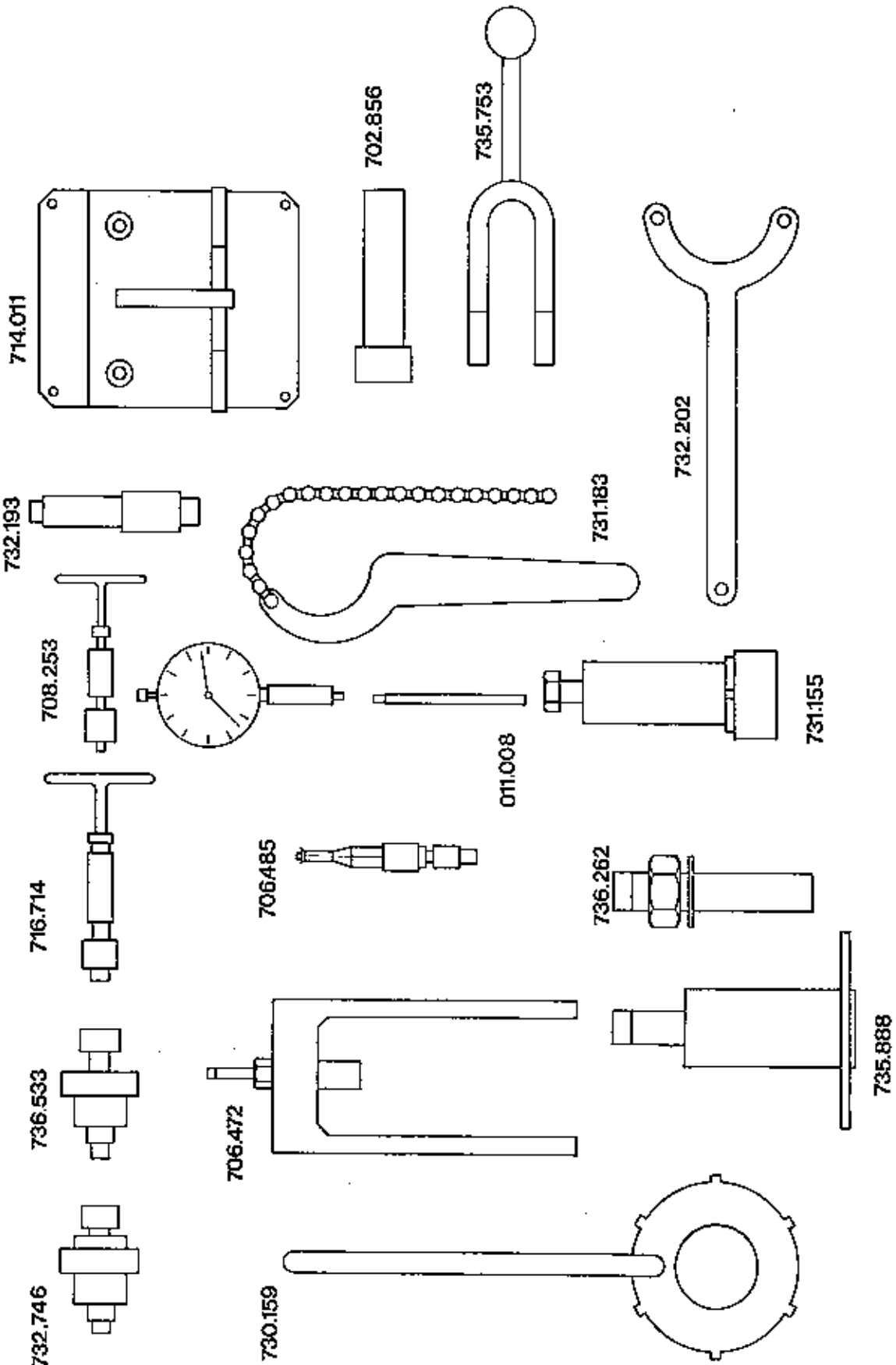

**ORODJE**

- izvijači (različne velikosti)
- kratki izvijači (različne velikosti)
- imbus ključi 3, 4, 5, 6.
- kombinirane klešče
- ploščate klešče
- klešče — papagajke
- klešče za segerjeve varovalke (notranje in zunanje)
- kladivo 400 gr.
- plastično kladivo
- ključi 8, 10, 11, 13, 17, 19, 22, 24, 30.

- Screwdrivers (of various sizes)
- Short screwdrivers (of various sizes)
- Allen keys 3, 4, 5, 6
- Combination pliers
- Flat nose pliers
- Multigrip pliers
- Pliers for SG-circlips (internal and external)
- Hammer 400 gr
- Plastic mallet
- Spanners 8, 10, 11, 13, 17, 19, 22, 24, 30

### MOTOR

Opis dela	ure
— de-in montaža motorja iz okvira	1
— razstavljanje in sestavljanje motorja z zamenjavo kateregakoli dela	3,1/2
— de-in montaža desnega pokrova z zamenjavo posameznih delov sklopke ali predležne gredi	1,1/4
— de-in montaža valja in bata	1/2
— zamenjava glave	1/4
— zamenjava ojnične puše	1
— zamenjava pretične ali zagonske ročice	1/4
— zamenjava levega pokrova	1/2
— zamenjava pogonskega verižnika	1/2
— zamenjava verige	1/4
— zamenjava olja v menjalniku	1/4

### ELEKTROINSTALACIJA

— zamenjava vžigalnika kpl.	1
— de-in montaža vžigalnika z zamenjavo kateregakoli sestavnega dela	1,1/2
— nastavitev vžiga	1/4
— zamenjava enega stikala na krmilu	1/2
— zamenjava stabilizatorja napetosti	1/4
— zamenjava releja smerokaza	1/3
— zamenjava zavornega stikala	1/4
— zamenjava sirene	1/4
— zamenjava zunanje vžigalne tuljave	1/4
— zamenjava zunanje svetilke	1/2
— zamenjava enega smerokaza	1/4
— de-in montaža ohišja merilnih ur ali posameznega dela	3/4
— de-in montaža žarometa z zamenjavo žarnic	1,1/4
— zamenjava ene žarnice smerokaza ali zadnje svetilke	1/4
— zamenjava kableskega spleta kpl.	3
— popravilo enega el. voda	1/2

### UPLINJAČ, DUŠILEC IZPUH

— zamenjava uplinjača kpl.	1/2
— zamenjava usisnega grla	1/4
— de-in montaža uplinjača s čiščenjem in zamenjavo kateregakoli sestavnega dela	3/4
— nastavitev uplinjača	1/4
— zamenjava dušilca kpl.	1/2
— zamenjava filtra	1/4
— zamenjava spojne cevi	1/4
— de-in montaža izpuha	1/4
— zamenjava posameznih delov izpuha	1/2
— čiščenje izpuha	1/2

### ENGINE

Description of work	Hr
Removing from and re-instaling the engine in the frame	1
Dismantling and re-assembling the engine along with replacing any part thereof	3-1/2
Removing and refitting the RH cover along with replacing individual clutch or countershaft parts	1-1/4
Removing and refitting the cylinder and piston	1/2
Replacing the cylinder head	1/4
Replacing the connecting rod bush	1
Replacing the gearshift or starter lever	1/4
Replacing the LH cover	1/2
Replacing the drive chain sprocket	1/2
Replacing the chain	1/4
Changing oil in the gearbox	1/4

### ELECTRICAL EQUIPMENT

Replacing the magneto assy.	1
Removing and refitting the magneto along with replacing any component thereof	1-1/2
Ignition timing	1/4
Replacing a switch on the handlebar	1/2
Replacing the voltage stabilizing tube	1/4
Replacing the direction indicator relay	1/3
Replacing the brake switch	1/4
Replacing the horn	1/4
Replacing the external ignition coil	1/4
Replacing the tail lamp or headlamp	1/2
Replacing a direction indicator	1/4
Removing and refitting the housing of speedometer and rev counter or individual parts thereof	3/4
Removing and refitting the headlamp along with replacing the bulbs	1-1/4
Replacing a direction indicator bulb or a tail lamp bulb	1/4
Replacing the cable harness assy.	3
Repairing an electric lead	1/2

### CARBURETTOR, INTAKE SILENCER, EXHAUST

Replacing the carburettor assy.	1/2
Replacing the intake manifold	1/4
Removing and re-installing the carburettor along with cleaning and replacing any of its components	3/4
Setting the carburettor	1/4
Replacing the intake silencer assy.	1/2
Replacing the filter	1/4
Replacing the connecting pipe	1/4
Removing and refitting the exhaust	1/4
Replacing individual exhaust parts	1/2
Cleaning the exhaust	1/2

### OKVIR, NIHAJNI KRAK

— zamenjava okvira kpl.	6,1/2
— zamenjava ležajne skodelice — prednje	1,1/2
— zamenjava nihajnega kraka ali kateregakoli sestavnega dela	1,1/2
— mazanje ležajnih puš nihajnega kraka	1
— zamenjava krmila	1,3/4
— zamenjava leve ali desne ročice kpl.	1/2
— zamenjava bovdena plina	3/4
— zamenjava bovdena sklopke	1/2
— zamenjava zvonca	1/4

### PREDNJE VILICE, BLAŽILCI

— zamenjava vilic kpl.	2
— zamenjava in mazanje ležajnih kroglic	1,1/4
— zamenjava zgornje vilične vezi ali spone krmila	1
— zamenjava olja v vilicah	1
— zamenjava ene noge vilic	1,1/2
— razstavljanje vilic z zamenjavo kateregakoli dela noge	2
— zamenjava zadnjega blažilca	1/2

### KOLESA, ZAVORE

— zamenjava prednjega — zadnjega kolesa kpl.	3/4
— zamenjava ležajev, vtične osi distančne puše	1,1/2

### KOLESA ZAVORE

— zamenjava plašča ali zračnice	1,1/4
— zamenjava pogona brzinomera	3/4
— centriranje žbičenega kolesa	1,1/2
— zamenjava pesta žbičenega kolesa	2,1/4
— zamenjava verižnega zobnika	3/4
— zamenjava nosilne plošče ali zavorne čeljusti	1
— zamenjava zavornega koluta	3/4
— zamenjava bovdena prednje zavore	1/2
— zamenjava zavornega droga — zadnje zavore	1/4
— zamenjava zavornih ploščic	1/4
— zamenjava olja v zavornem sistemu	1/4
— zamenjava delov tlačnega cilindra	3/4
— zamenjava delov zavornega cilindra	1

### OPREMA

— zamenjava rezervoarja	1/4
— zamenjava pipice za gorivo	1/4
— zamenjava ene maske	1/4
— zamenjava sedeža	1/4
— zamenjava prednjega ali zadnjega blatnika	1/4
— zamenjava ščitnika verige	1/4

### FRAME, SWINGING ARM, HANDLEBAR

Replacing the frame assy.	6-1/2
Replacing the front bearing cup	1-1/2
Replacing the swinging arm leg or any of its components	1-1/2
Lubricating the swinging arm leg bearing bushes	1
Replacing the handlebar	1-3/4
Replacing the LH or RH lever assy.	1/2
Replacing the throttle control cable	3/4
Replacing the clutch control cable	1/2
Replacing the bell	1/4

### FRONT FORK, SHOCK ABSORBERS

Replacing the fork assy.	2
Replacing and lubricating the bearing balls	1-1/4
Replacing the top fork yoke or handlebar clamp	1
Changing oil in the fork	1
Replacing a fork leg	1-1/2
Dismantling the fork along with replacing any of the fork leg parts	2
Replacing the rear shock absorber	1/2

### WHEELS, BRAKES

Replacing the front or the rear wheel assy.	3/4
Replacing the bearings, the wheel spindle, the spacer	1-1/2
Replacing the tyre or inner tube	1-1/4
Replacing the speedometer drive gearbox	3/4
Aligning the spoked wheel	1-1/2
Replacing the spoked wheel hub	2-1/4
Replacing the chain sprocket	3/4
Replacing the brake plate or brake shoe	1
Replacing the brake disc	3/4
Replacing the front brake control cable	1/2
Replacing the rear brake rod	1/4
Replacing the brake pads	1/4
Changing oil in the brake system	1/4
Replacing the brake pump parts	3/4
Replacing the brake claw parts	1

### EQUIPMENT

Replacing the fuel tank	1/4
Replacing the fuel feed tap	1/4
Replacing a side cover	1/4
Replacing the seat	1/4
Replacing the front or rear mudguard	1/4
Replacing the chain guard	1/4